

Li'l Darling Ruth presents:

1958 FORD

AIR CONDITIONING

SHOP MANUAL



FORD DIVISION • FORD MOTOR COMPANY

FOREWORD

This manual gives service information on the Ford SelectAire Conditioner and the Ford PolarAire Conditioner, which are available as optional equipment on 1958 Ford cars and Thunderbird.

The manual is divided into three chapters as shown in the Table of Contents. Each chapter is divided into sections which will enable you to select that particular portion in which you are interested.

Chapter ONE discusses general refrigeration theory, describes the operation of the air conditioners, and gives the location of the various units on the vehicle. Each unit is illustrated to aid you in its identification.

The maintenance items which should be periodically checked, along with trouble shooting procedures, are given in Chapter TWO. Test procedures required for a complete check of the system are also given.

Unit replacement is covered in Chapter THREE. The removal, disassembly, inspection, and installation of each unit is completely described.

Before installation or repair of a Ford air conditioner, the mechanic and/or Ford Dealer must comply with the following:

Be authorized by the Ford District Service Department.

Comply with all state and local ordinances with regard to the installation or repair of automotive air conditioning systems.

Comply with all state and local ordinances concerning the storage of refrigerant.

Use only Refrigerant-12 (Freon-12, Isotron-12 or Genetron-12) in the Ford air conditioner.

The descriptions and specifications contained in this manual were in effect at the time the book was approved for printing. Ford Division of Ford Motor Company reserves the right to discontinue models at any time, or change specifications or design, without notice and without incurring obligation.

SERVICE DEPARTMENT
FORD DIVISION
FORD MOTOR COMPANY

TABLE OF CONTENTS

Subject	Page	Subject	Page
Foreword.....	1	Insufficient or No Cooling.....	16
		Other System Malfunctions.....	18
Chapter ONE—REFRIGERATION THEORY AND SYSTEM OPERATION.....	3	Section 4. Test Procedures.....	18
Section 1. Refrigeration Theory.....	3	Manifold Gauge Set Installation.....	18
Heat Transfer.....	3	Checking for Leaks.....	18
Latent Heat of Fusion.....	3	Discharging the System.....	19
Latent Heat of Vaporization.....	4	Charging the System.....	20
Effect of Pressure on Vaporization and Condensation.....	4	Checking System Pressures.....	20
Vaporization and Condensation of Refrigerant.....	4	Checking System Temperatures.....	21
Basic Air Conditioning System.....	4	Thermostatic Switch Test.....	22
		Expansion Valve Tests.....	23
		Electrical Unit Current Draw.....	23
Section 2. System Operation.....	5	Chapter THREE—UNIT REPLACEMENT.....	24
Receiver Unit.....	5	Section 1. Heater, Evaporator, and Related Parts..	24
Evaporator Unit.....	5	Blower and Motor Assembly—Car PolarAire..	24
Expansion Valve.....	5	Blower and Motor Assembly—Car SelectAire..	24
Liquid Sight Glass.....	7	Blower and Motor Assembly— Thunderbird SelectAire.....	25
Compressor Unit.....	7	Thermostatic Switch.....	25
Magnetic Clutch.....	8	Expansion Valve.....	26
Thermostatic Switch.....	8	Heater Core.....	27
Service Valves.....	9	Evaporator.....	27
Section 3. Control Operation.....	9	Control Unit.....	29
Control Panel.....	9	Section 2. Condenser and Receiver.....	29
Air Outlet Controls.....	12	Condenser.....	29
		Receiver.....	30
Chapter TWO—MAINTENANCE, TROUBLE SHOOTING, AND TEST PROCEDURES.....	13	Section 3. Compressor Service.....	30
Section 1. Safety Precautions.....	13	Isolating the Compressor.....	30
Section 2. Maintenance and Adjustments.....	14	Valve Plate Replacement.....	31
Maintenance.....	14	Service Valve Replacement.....	31
Adjustments.....	14	Compressor Replacement.....	31
Section 3. Trouble Shooting Procedures.....	16	Crankshaft Seal Replacement—Tecumseh.....	32
		Crankshaft Seal Replacement—Lehigh.....	33
		Belt Replacement.....	34

Chapter 1

Refrigeration Theory and System Operation

Section	Page
1 Refrigeration Theory.....	3
2 System Operation.....	5
3 Control Operation.....	10

The Ford SelectAire Conditioner is available as optional equipment on all 8-cylinder 1958 cars and Thunderbirds. The PolarAire conditioner is available on all 8-cylinder 1958 cars. This chapter discusses basic

refrigeration theory, describes the Ford SelectAire and PolarAire units, shows how these units utilize the basic refrigeration principles, and gives a description of the system controls.

1. REFRIGERATION THEORY

Refrigeration is normally thought of as the process of making something cold, but there is actually no such thing as coldness. Coldness is merely the absence of heat. Thus, the story of refrigeration is the story of removing heat from the substance to be refrigerated, whether that substance be food in an ice-box or air in the passenger compartment of an automobile. Contrary as it may seem, refrigeration developed from a knowledge of the basic properties of heat and how it behaves in various substances. This development began when scientists discovered the natural laws of heat and progressed as engineers applied the laws to practical use.

Before discovering the laws of heat, the scientists first had to answer the question, "What is heat?" Heat, like electricity, is not a tangible object; yet its effects can be measured, and it can be made to perform useful services.

The following paragraphs explain the natural laws of heat and how they are applied to refrigeration.

Heat Transfer

If two substances of different temperature are placed near each other, the heat in the warmer substance will always travel to the colder substance until both are of equal temperature. For example, a cake of ice in an ice box does not communicate its coldness to the bottle of milk standing nearby. Rather, in obedience to nature's law, the heat in the warm milk automatically flows into the ice which has a lesser degree of heat.

In order to determine the amount of heat that transfers from one substance to another, science has established a definite standard of measurement called the British Thermal Unit or BTU. One BTU is the amount of heat required to raise the temperature of one pound of water 1°F. For example, to raise the temperature of

one pound of water from 32°F. to 212°F., one BTU of heat must be added for each degree rise in temperature or a total of 180 BTU's of heat. Conversely, in order to lower the temperature of one pound of water from 212°F. to 32°F., 180 BTU's of heat must be removed from the water.

Latent Heat of Fusion

If a bottle of milk at 70°F. is placed next to a cake of ice at 32°F., heat will flow from the milk to the ice. As a result, the temperature of the milk begins to drop; but here a strange thing occurs. Even though a large amount of heat travels from the milk to the ice, the temperature of the ice remains at 32°F. The ice however, starts to melt or change from the solid to the liquid state; and it continues to melt until the milk temperature decreases to 32°F. If a thermometer is placed in the water immediately after the ice has melted, the water will also show a temperature of 32°F.

There is no increase in either the ice or water temperature, even though the milk gave off 144 BTU's of heat for each pound of water that melted from the ice. This heat appears to have gone into hiding. In the process of melting, the heat was absorbed by the ice and disappeared in the water. If the same water at 32°F. were placed in contact with a colder substance, the hidden heat would reappear and flow into the colder substance. The water would then be frozen back to ice at 32°F. Scientists call this heat the latent (meaning hidden) heat of fusion.

Among the solids, then, ice is an effective refrigerant in changing to a liquid, but it is bulky and needs constant replenishment. The search for a better refrigerant led to the discovery that heat absorption also takes place in changing a liquid to a gas.

Latent Heat of Vaporization

Place one pound of water at 32°F. in a container over a flame. With each BTU of heat that the water absorbs from the flame, its temperature rises 1°F. Thus, after it has absorbed 180 BTU's of heat, the water reaches a temperature of 212°F. Here another law of nature is encountered. Even though the flame continues to give its heat to the water, the temperature of the water remains at 212°F. The water, however, starts to boil or change from the liquid to the gaseous state, and it continues to boil until the water has passed off into the atmosphere as vapor. If this vapor were collected in a container and checked with a thermometer, it would show a temperature of 212°F. In other words, there was a rise of only 180°F. (from 32 to 212) in the water and vapor temperature even though the flame applied many more than 180 BTU's of heat. In this case, the heat is absorbed by the liquid in the process of boiling and disappears in the vapor. If the vapor were brought in contact with cool air, the hidden heat would reappear and flow into the cooler air as the vapor condensed back to water. Scientists refer to this natural law as the latent (hidden) heat of vaporization.

Water has a latent heat of vaporization of 970 BTU's and a boiling point of 212°F. This means that 1 pound of water at 212°F. will absorb 970 BTU's of heat in changing to vapor at 212°F. Conversely, the vapor will give off 970 BTU's of heat in condensing back to water at 212°F.

This tremendous heat transfer, that occurs when a liquid evaporates or a vapor condenses, forms the basic principle of all conventional refrigeration systems.

Effect of Pressure on Vaporization and Condensation

The boiling or condensation point of a material increases or decreases according to the pressure exerted on it. For example, water will change to vapor or the vapor will condense back to water at a temperature of 212°F. only under normal atmospheric pressure at sea level. At pressures higher or lower than normal, the boiling and condensing can occur only at temperatures correspondingly higher or lower than 212°F.

To illustrate with water as a refrigerant, place a bottle of milk at room temperature next to boiling water at 212°F. (normal pressure). In this case, the heat flows from the water to the milk instead of from the milk to the boiling water, because the temperature of the boiling water is higher than the milk temperature. In order to cool the milk, the boiling point of the water would have to be reduced from 212°F. to a temperature below that of the milk. This lowering of the boiling point would require such a tremendous reduction of pressure as to make water an impractical refrigerant in this case.

In order to make practical use of the heat transfer that occurs when a liquid boils, chemists have developed a number of other liquids which boil at a very low temperature under normal pressure conditions. Refrigerant-12, which is most commonly used in air conditioning systems and refrigerators, boils at a sub-zero temperature under normal pressure.

Vaporization and Condensation of Refrigerant

In a modern home refrigerator a bottle of milk is placed in a box beside a set of coils called the evaporator. Liquid refrigerant is metered into the evaporator by an expansion valve. Refrigeration is accomplished when the refrigerant boils in the evaporator. The heat from the milk is absorbed by the liquid refrigerant in the process of boiling, and disappears in the refrigerant vapor, which is pumped out of the evaporator to another set of coils located outside the box. The outside set of coils is called the condenser. Here the refrigerant vapor condenses back to liquid so that it can return to the evaporator and be used again for absorbing heat.

If the refrigerant vapor is to condense, it must have a boiling or condensation point higher than the temperature of the air surrounding the condenser coils. As previously stated, however, Refrigerant-12 has a boiling point several degrees below zero under normal pressure conditions. Therefore, a compressor is employed to pump the refrigerant vapor into the condenser under very high pressure. With the increase in pressure, the condensation point is raised from below zero to a point above the temperature of the surrounding air. The refrigerant vapor can now condense back to liquid and, in so doing, the heat, that was absorbed from the milk, is now given off to the outside air surrounding the condenser coils.

Basic Air Conditioning System

In any automotive air conditioning system, the evaporator, is exposed to air flow from the passenger compartment. The expansion valve releases liquid refrigerant into the evaporator coils, the heat from the air is absorbed by the boiling refrigerant and disappears in the refrigerant vapor. The refrigerant vapor containing the hidden heat, is pumped out of the evaporator by a compressor and forced under high pressure to the condenser which is located outside the passenger compartment. In the condenser, the refrigerant vapor condenses back to liquid and the heat, that was absorbed from the passenger compartment and hidden in the vapor, now reappears and passes off into the outside air stream.

The liquid refrigerant under high pressure, now passes from the condenser to a receiver where it is stored for

re-use. The liquid refrigerant will not boil while it is stored in the receiver, because it is under high pressure which maintains the boiling point of the refrigerant above the temperature of the surrounding air. Thus, no heat can transfer from the outside air to the refrigerant in the receiver.

The receiver is connected to the expansion valve in the evaporator where the cooling cycle starts over again. When the expansion valve is opened, the high pressure liquid refrigerant from the receiver passes through an orifice in the expansion valve which releases the refrigerant into the evaporator at a greatly reduced pressure. Thus, the temperature, at which the liquid refrigerant will boil, is reduced below car air temperature. Now the liquid refrigerant, by absorbing heat from the car air, begins to vaporize.

2. SYSTEM OPERATION

Two air conditioning units are available for 1958 vehicles. The SelectAire Conditioner and the PolarAire Conditioner.

The cooling portion of both air conditioners uses a receiver, and expansion valve, an evaporator, a compressor, and a condenser. These parts, as just discussed, are the standard units which are used in any air cooling system. Besides these major cooling components, the SelectAire Conditioner unit uses a liquid sight glass, an oil separator (integral with the compressor), a cooling unit thermostatic switch, a heater thermostat, a heater core, a blower assembly, a control unit and the necessary connecting wires, ducts and hoses.

Figure 1 shows the entire SelectAire cooling system in schematic form. Arrows indicate the direction of refrigerant flow. Figure 2 shows the electrical control circuit.

The PolarAire Conditioner is the same as the SelectAire unit except that the evaporator is different in shape, and is separate from the heater, mounts under the center of the instrument panel on the tunnel (Fig. 3), has no additional air ducts, and has controls which are integral with the unit.

Receiver Unit

The air cooling system stores the liquid Refrigerant-12 under pressure in a combination receiver and dehydrator (Fig. 4). The pressure in the receiver varies from about 100 to 250 psi (pounds per square inch), depending on the surrounding air temperature and compressor speed. The SelectAire receiver and condenser comes charged and marked with the total weight, so that any leak can be detected before assembly.

The dehydrator serves the purpose of removing any traces of moisture that may have accumulated in the system. Even small amounts of moisture will cause an air cooling unit to malfunction. A rupture disc is

It may seem difficult to understand how heat can be transferred from a comparatively cooler car passenger compartment to the hot outside air. The answer lies in the difference between the refrigerant pressure that exists in the evaporator and the pressure that exists in the condenser. In the evaporator, the expansion valve reduces the pressure and thereby reduces the boiling point below the temperature of the passenger compartment. Thus, heat transfers from the passenger compartment to the boiling refrigerant. In the condenser, the compressor raises the condensation point above the temperature of the outside air. Thus, the heat transfers from the condensing refrigerant to the outside air. The expansion valve and the compressor simply create pressure conditions that permit the laws of nature to function.

screwed into the outlet of the receiver (Fig. 4). This disc will rupture and release the refrigerant when the pressure in the system reaches 475 to 575 psi.

Evaporator Unit

When the cooling system is in operation, the liquid Refrigerant-12 flows from the combination receiver and dehydrator unit through a flexible hose to the evaporator (cooling unit) (Figs. 5 and 6), where it is allowed to evaporate at a reduced pressure. The Thunderbird evaporator is similar to the Ford car evaporator. The SelectAire evaporator is mounted on the passenger compartment side of the dash, at the same location as the standard heater (Fig. 7). The PolarAire unit mounts as shown in Fig. 3.

Expansion Valve

The rate of refrigerant evaporation is controlled by an expansion valve (Figs. 6 and 8) which allows only enough refrigerant to flow into the evaporator to keep the evaporator operating efficiently, depending on its heat load.

The expansion valve consists of the valve and a temperature sensing capillary tube and bulb (Figs. 6 and 8). The bulb is clamped to the outlet pipe of the evaporator. Thus, the operation of the valve is controlled by the temperature of the evaporated liquid at the point where it leaves the evaporator or cooling unit. An equalizer connection at the SelectAire evaporator outlet applies evaporator outlet pressure to one side of the valve diaphragm. The PolarAire valve is internally equalized. Thus, the valve is controlled by both evaporator outlet temperature and outlet pressure.

The restricting effect of the expansion valve at the evaporator causes a low pressure on the low pressure

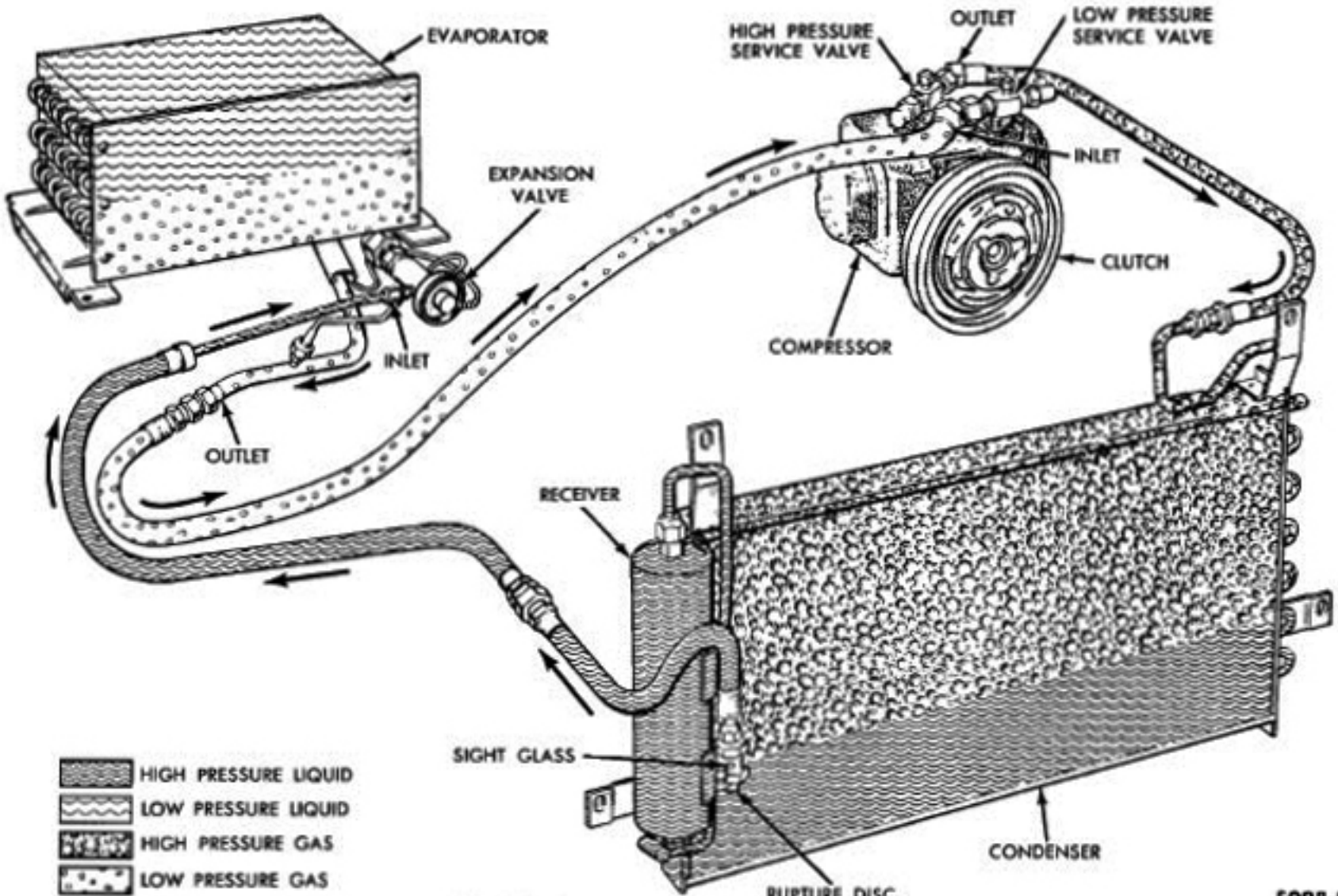

Fig. 1—Air Cooling System—SelectAir

5098-B

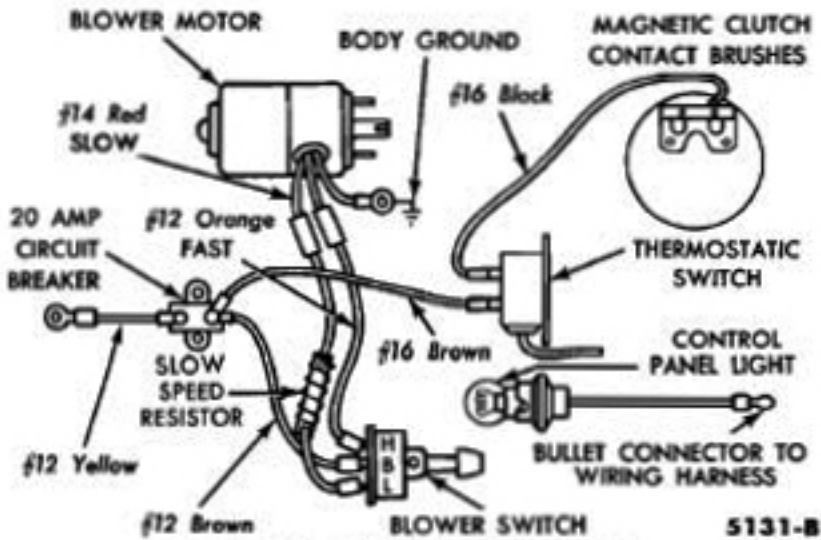

Fig. 2—Electrical Control Circuit



Fig. 3—PolarAir Conditioner Installation

5263-A

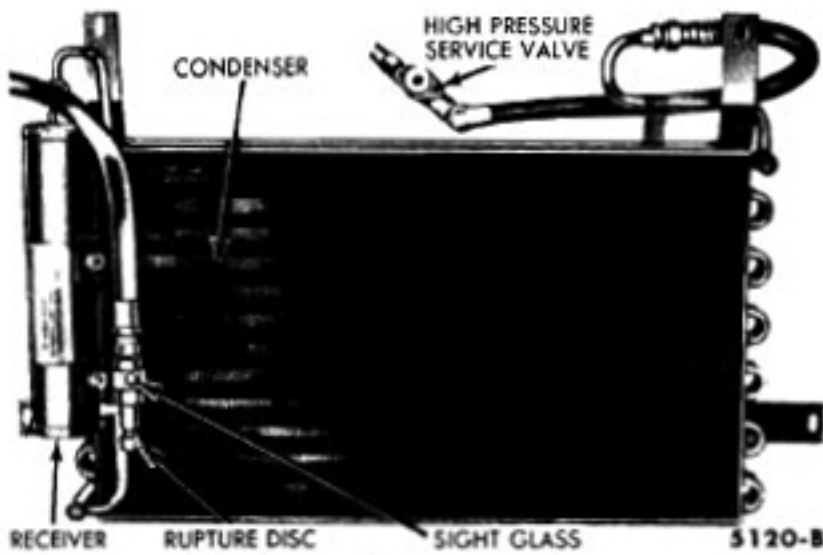

Fig. 4—Receiver and Condenser

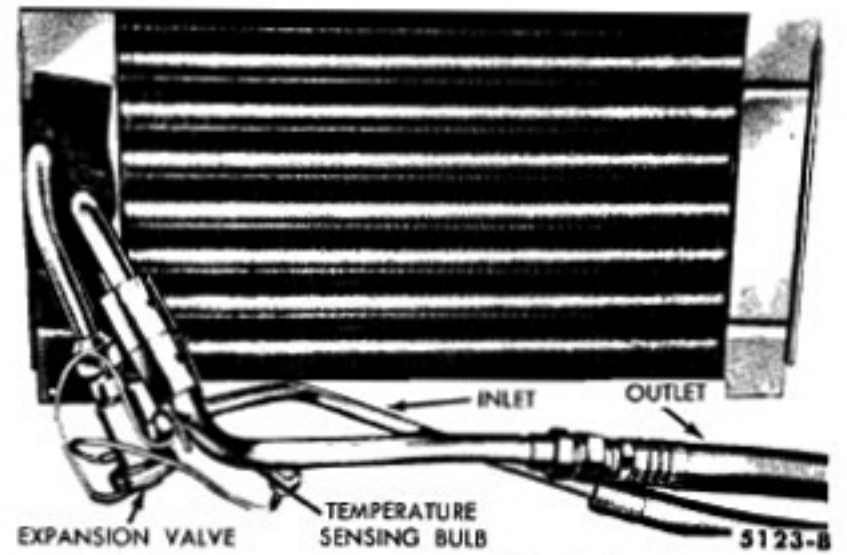

Fig. 5—Evaporator Core Assembly—SelectAire, Car

side of the system of 16-55 psi, depending on the surrounding air temperature and compressor speed.

Liquid Sight Glass

A liquid sight glass is mounted at the receiver outlet (Fig. 4). The sight glass is used to check whether or not there is enough liquid refrigerant in the system. At no time should bubbles be seen in the sight glass. The sight glass is normally protected by a rotating cover. Figure 4 shows the cover rotated so that the glass may be observed.

Compressor Unit

The evaporated refrigerant leaving the evaporator (now in the form of a gas), at a pressure of 16-55 psi

is pumped by the compressor, located on the engine (Figs. 9 and 10), into the top of the condenser (Fig. 4), located in front of the radiator.

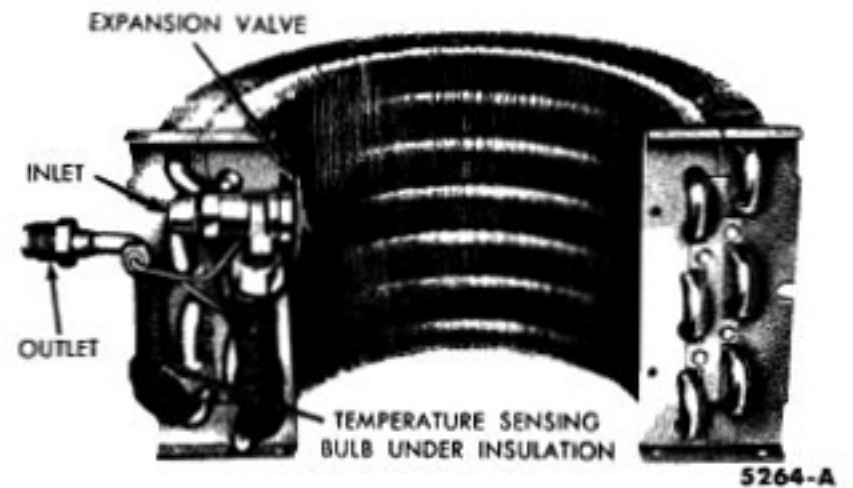

Fig. 6—Evaporator Core Assembly—PolarAire

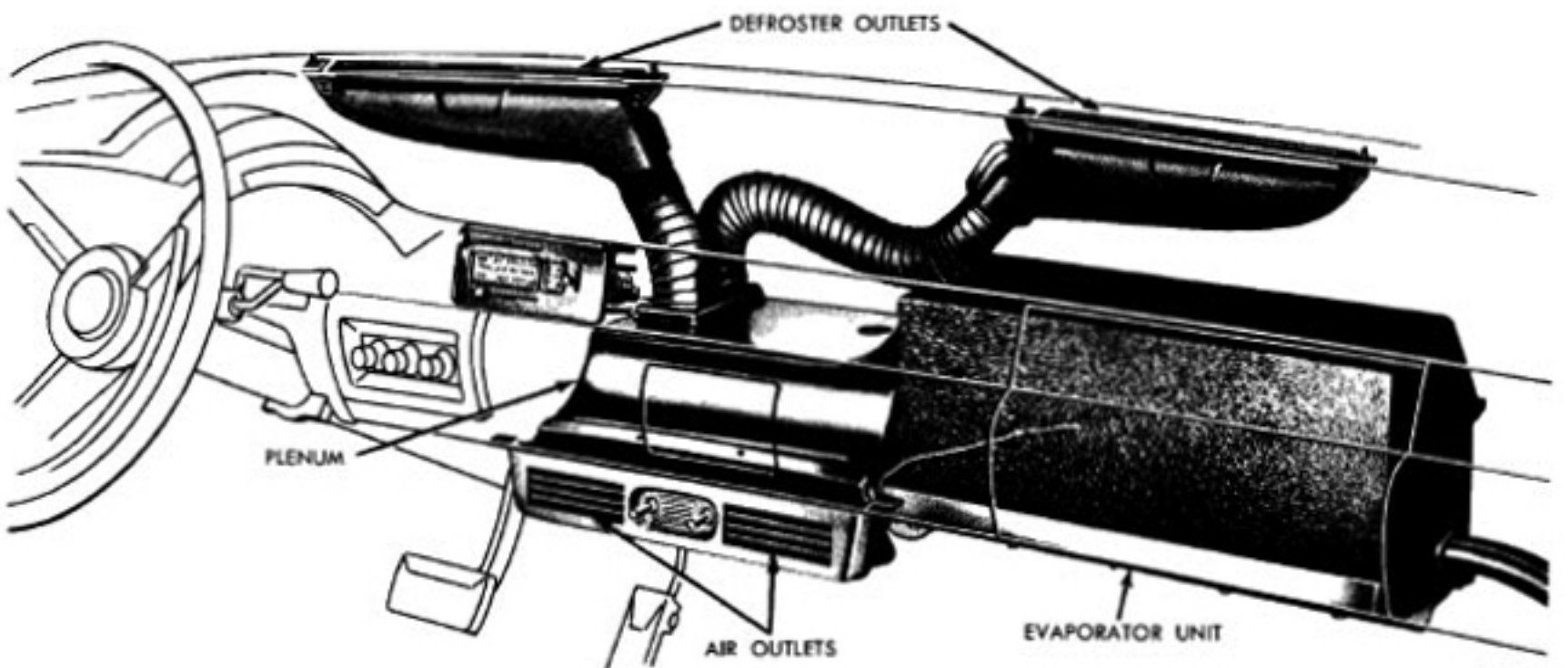

Fig. 7—SelectAire Conditioner Installation—Car

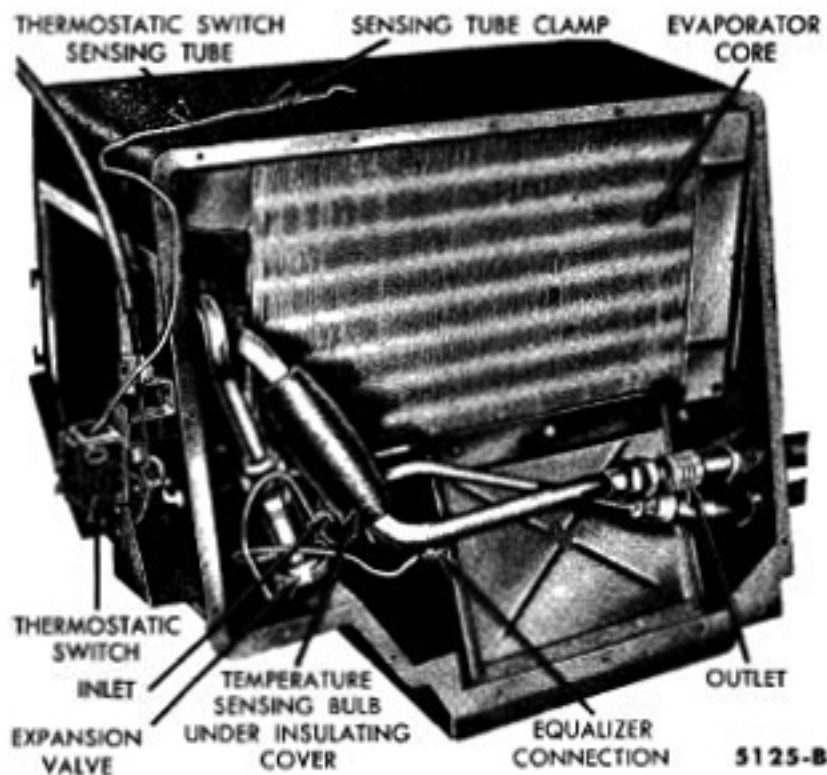

Fig. 8—Expansion Valve—Car

The compressor maintains a pressure on its high pressure side of from 100-250 psi, depending on the surrounding air temperature and compressor speed.

As the now heated and compressed refrigerant gas flows down through the condenser, it is cooled by air passing between the sections of the condenser, and the cooled, compressed refrigerant gas condenses to liquid refrigerant which then flows back into the receiver.

Magnetic Clutch

It is necessary to control the amount of cooling that the system produces. To accomplish this, the compressor is cut in and out of operation by the use of a magnetic

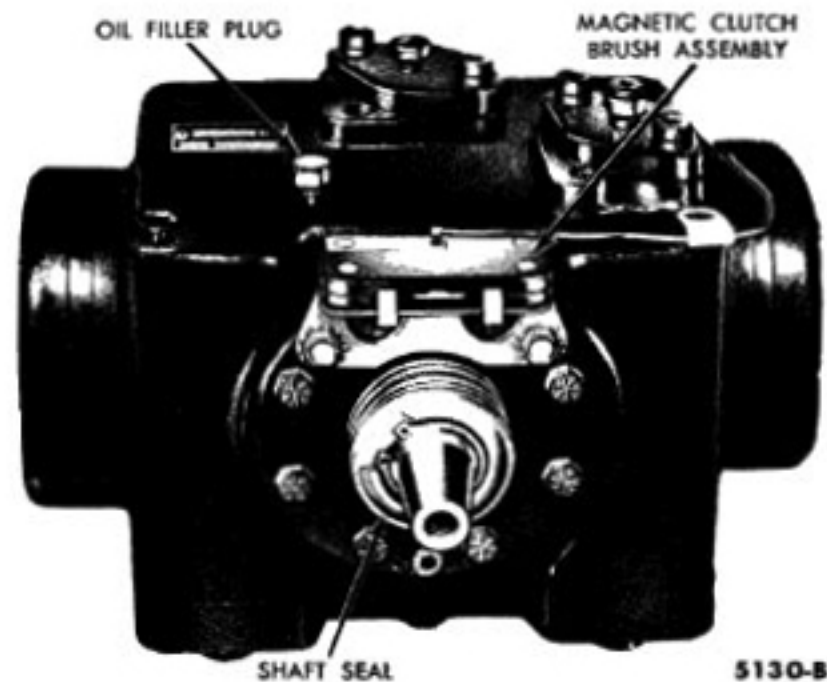

Fig. 9—Compressor—Tecumseh

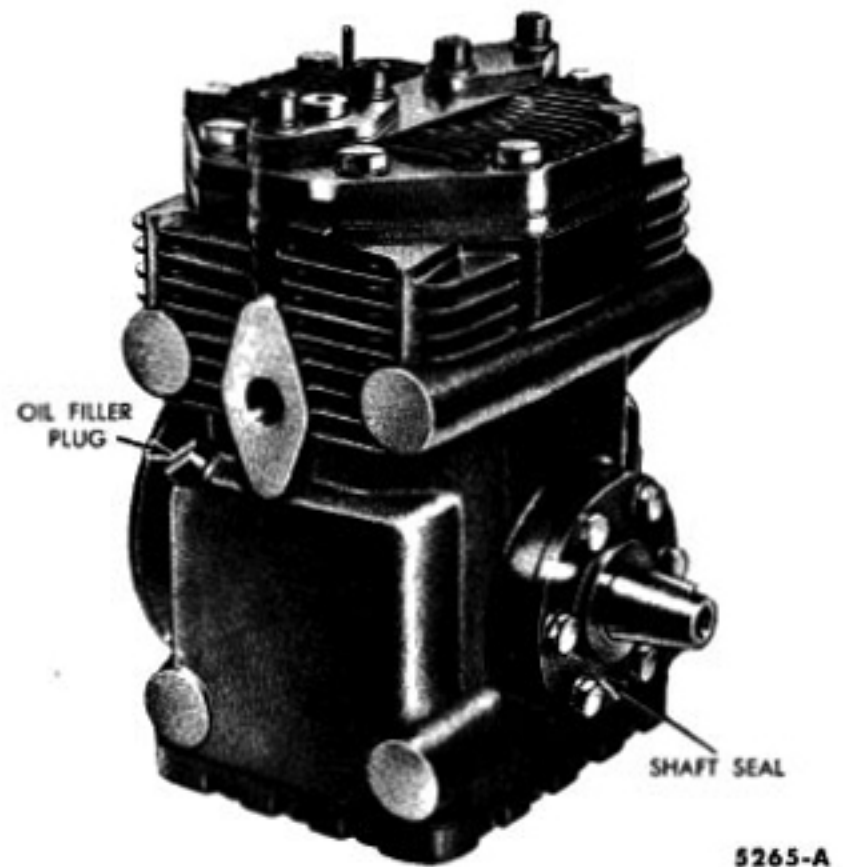

Fig. 10—Compressor—Lehigh

clutch pulley mounted on the compressor crankshaft (Fig. 11). The magnetic clutch is controlled by a thermostatic switch which is mounted on the evaporator case with its temperature sensing tube inserted in the fins of the evaporator core. (Figs. 8 and 12).

Thermostatic Switch

The thermostatic switch controls the operation of the compressor by controlling the compressor magnetic clutch. The temperature sensing tube of the switch is placed in contact with the evaporator fins. When the

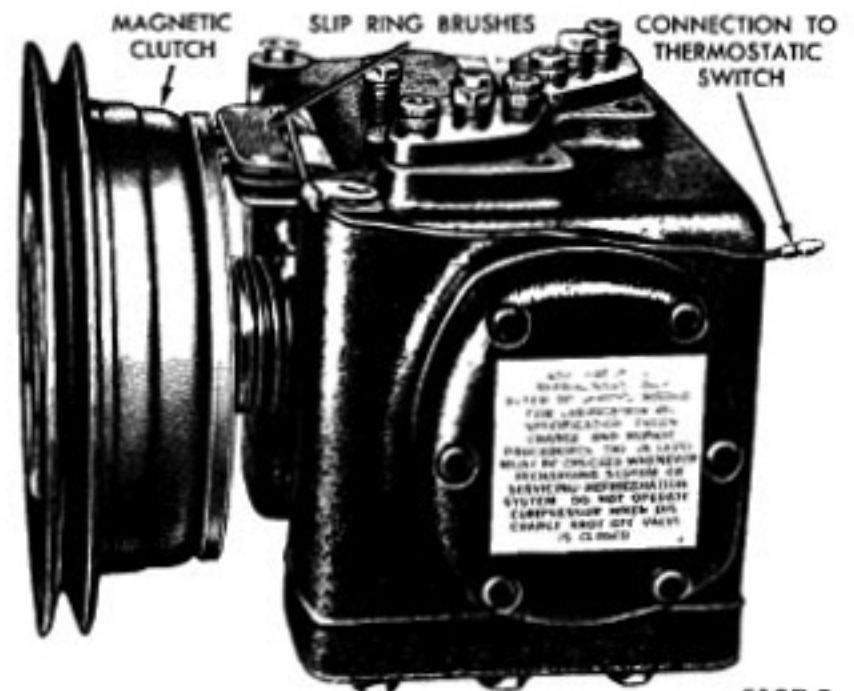

Fig. 11—Magnetic Clutch

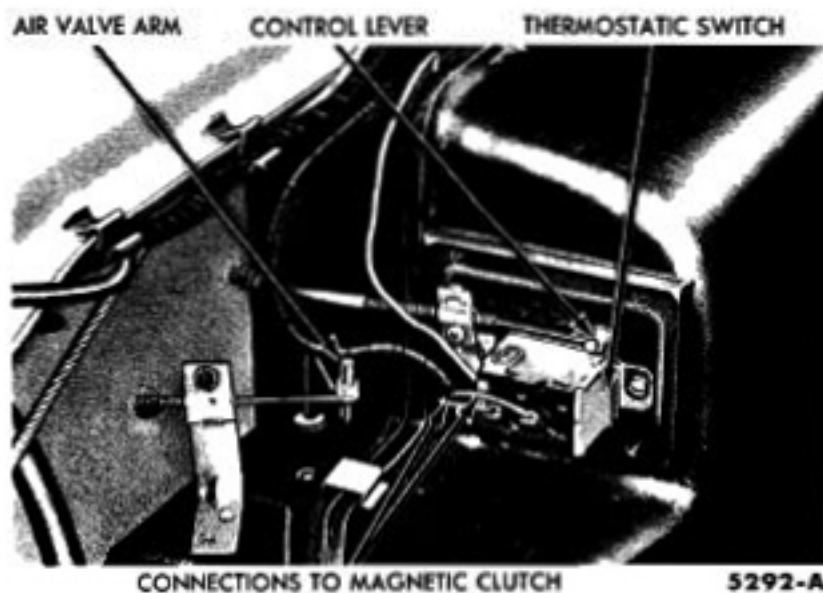

Fig. 12—Thermostatic Switch—Thunderbird

temperature of the evaporator becomes too cold, the thermostatic switch opens the magnetic clutch electrical circuit disconnecting the compressor from the engine. Refrigerant continues to flow until the high and low pressures equalize. When the temperature of the evaporator rises to the upper limit at which the thermostatic switch is set, the thermostatic switch closes and energizes the magnetic clutch. This connects the compressor to the engine and cooling action begins again.

When the ignition switch is off, or the cooling control (Figs. 13, 14 and 15), is in the off position, the magnetic

clutch is not energized, and the cooling system can not operate.

When the ignition switch is on (engine running), and the cooling control is in the cooling range, the magnetic clutch is energized, the compressor is connected to the engine and the cooling system is in operation.

The thermostatic switch may be adjusted to maintain an average evaporator temperature of from 30°-60°F. The thermostatic switch operating differential temperature at any one setting is 6°F. The switch is controlled by the cooling control (Figs. 13, 14 and 15). The further (to the right on cars—to the left on Thunderbirds) that the control is moved; the cooler the setting of the thermostatic switch.

Service Valves

The service valves are used to test and service the cooling system (Fig. 1). The high pressure service valve, mounted at the outlet to the compressor, allows access to the high pressure side of the system for attaching a pressure gauge, or a servicing hose.

The low pressure valve, mounted at the inlet to the compressor, allows access to the low pressure side of the system for attaching a pressure gauge, or a servicing hose.

Both service valves may be used to shut off the rest of the system from the compressor during compressor service.

3. CONTROL OPERATION

The operating controls for the PolarAire Conditioner are shown in Fig. 13. In addition to these controls there are adjustable air louvers at each side and at the front of the evaporator housing (Fig. 18).

Figure 7 shows the SelectAire Conditioner installation in the passenger car compartment.

The operating controls for the SelectAire Conditioners consist of the control panel (Figs. 14 and 15) and the instrument panel air outlet register assemblies (Figs. 16 and 17).

Control Panel

CAR SELECTAIRE. The control panel (Fig. 14) is mounted in the opening normally used for the standard heater control. The cooling control lever (top lever) controls the temperature setting of the thermostatic switch and the evaporator assembly air valve.

When the cooling control lever is at the off position (Fig. 14), the thermostatic switch is held open and the evaporator air valve is closed (dashed position of the valve Fig. 19), the compressor is thus disconnected

from the engine and the air circulation is cut off from the evaporator, all of the air can now go through the heater core.

With the cooling control lever in the off position, movement of the heating control lever (Fig. 14) to the right



Fig. 13—Controls—PolarAire

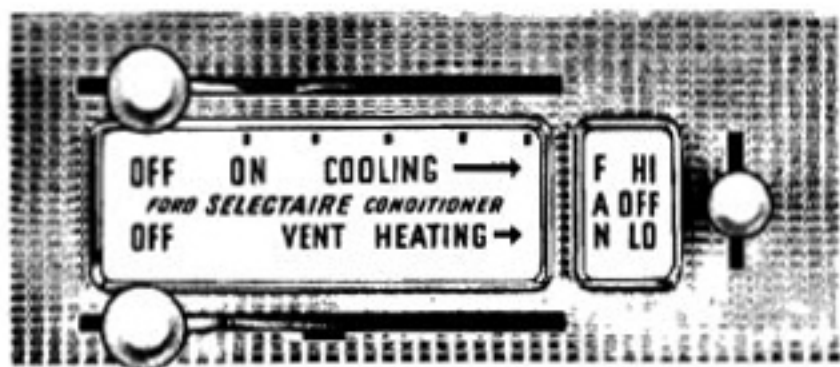
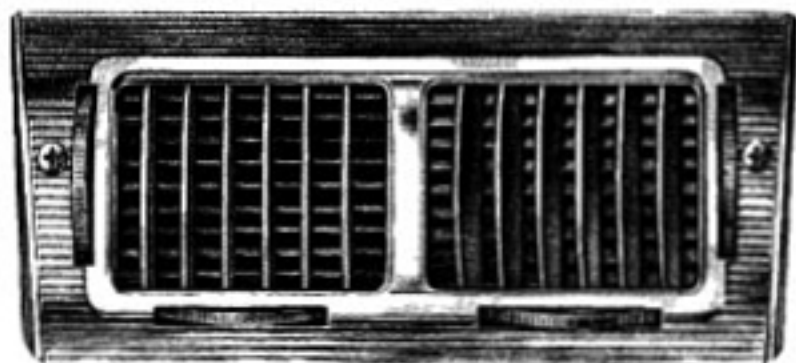
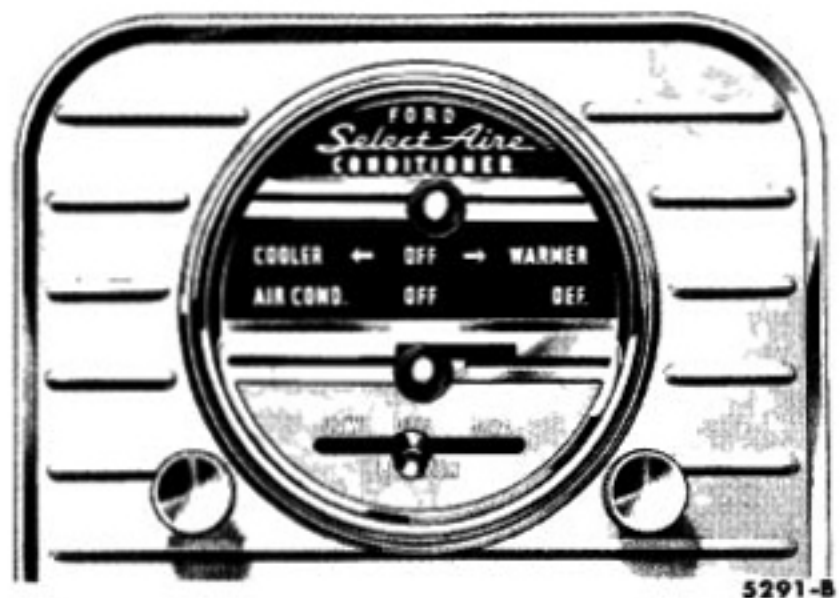

Fig. 14—Control Panel—Car



5293-A

Fig. 17—Air Outlets—Thunderbird



5291-B

Fig. 15—Control Panel—Thunderbird



5247-A

Fig. 18—Air Outlets—PolarAire

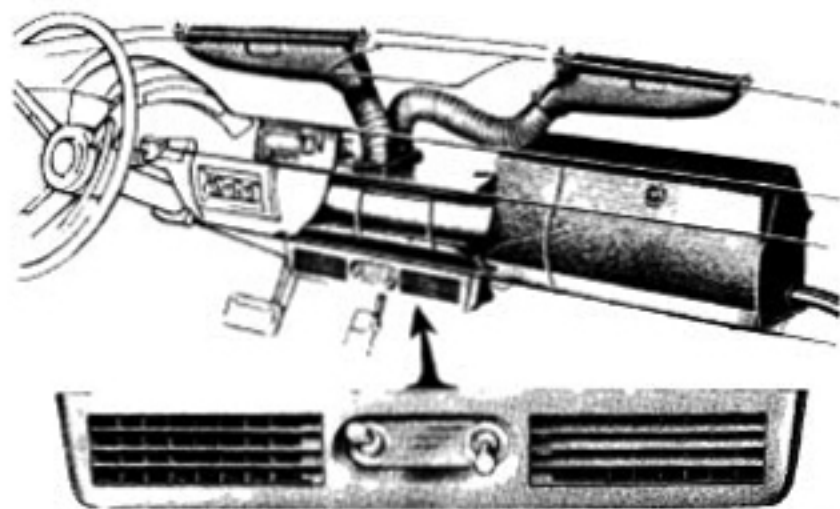

5134-B

Fig. 16—Air Outlets—Car

into the heating position, opens the vacuum operated water valve, and heat is obtained. As movement of the heating control lever past the vent position closes the recirculating air duct (Fig. 20), recirculated heated air cannot be obtained.

When cooling is desired, the heating control lever is moved to the left to the off position closing the water valve, closing the outside air inlet and opening the recirculating air duct (Fig. 20). The cooling control valve is then moved to the cooling position which energizes the

magnetic clutch and opens the evaporator air valve (solid position of the valve Fig. 19). The blower will then draw air from the passenger compartment and force it through the evaporator for cooling. The position of the cooling control lever sets the temperature of the evaporator anywhere between the limits of 28°-63°F. Movement of the heating control lever from the off position to the vent position will bleed in proportionate amounts of fresh outside air from the cowl air intake, depending on the movement of the lever from the off position. The outside air is mixed with the recirculated air just before it goes through the evaporator.

THUNDERBIRD SELECTAIRE. The Thunderbird Select-Aire control (Fig. 15), is mounted at the same location as the heater control, directly below the instrument panel on the tunnel.

When the upper control lever is moved from the OFF position, the cooling or heating thermostats are actuated; heating to the right; cooling to the left. The distance from the OFF position determines the amount of heating or cooling.

The middle control lever (Fig. 15) operates the de-

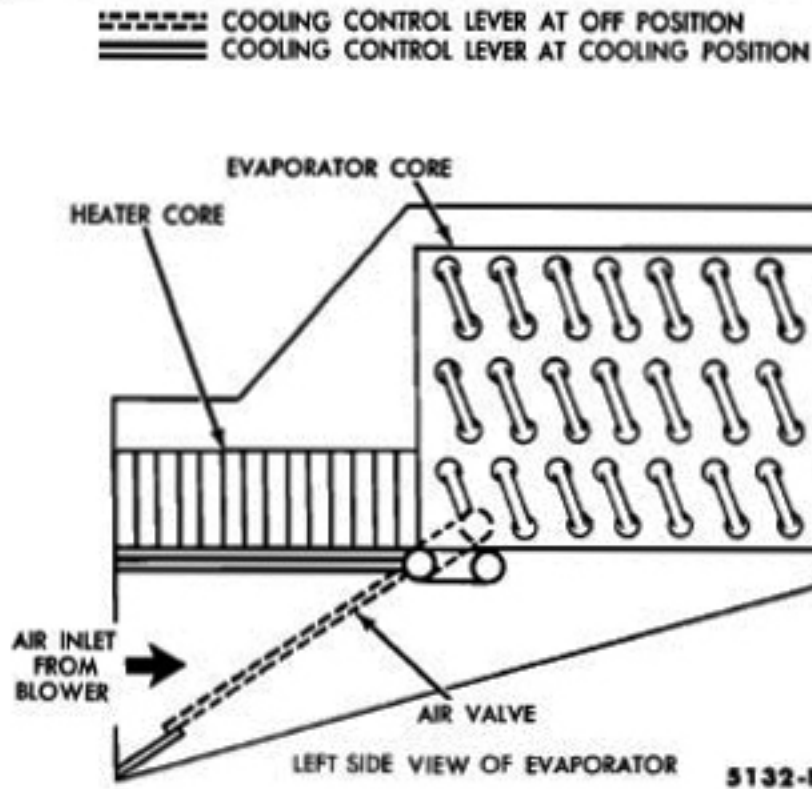

Fig. 19—Evaporator Air Valve—Car

froster valve only. When the lever is in the OFF position, the defroster outlets in the plenum chamber are closed and the plenum chamber is open to the passenger compartment. Moving the middle lever to the DEF position closes the plenum outlets to the passenger compartment and opens the defroster outlets to the windshield.

The bottom control lever (Fig. 15) operates the blower motor through a three position switch for OFF, LOW and HIGH speed.

The lower left control knob (Fig. 15) actuates the evaporator-heater (blower outlet) air valve. When the knob is pulled out, the outlet to the heater core is closed and the opening from the blower to the evaporator is open (Fig. 21). Pushing the left control knob in, closes the passage from the blower to the evaporator and opens the heater core to the blower.

The lower right control knob (Fig. 15) actuates the cowl air inlet (blower inlet) valve. When the knob is pulled out, the opening from the passenger compartment is closed off from the blower and the cowl vent is open to the blower allowing fresh air to be delivered to the blower (Fig. 21). Pushing the right hand knob in closes off the cowl vent from the blower and opens the passenger compartment to the blower.

For either cooling or heating the center (defrost) control lever should be at the OFF position and the lower (blower) control lever can be moved either to the HIGH or LOW position depending upon the amount of air circulation desired.

For cooling action, the remaining controls should be set as follows:

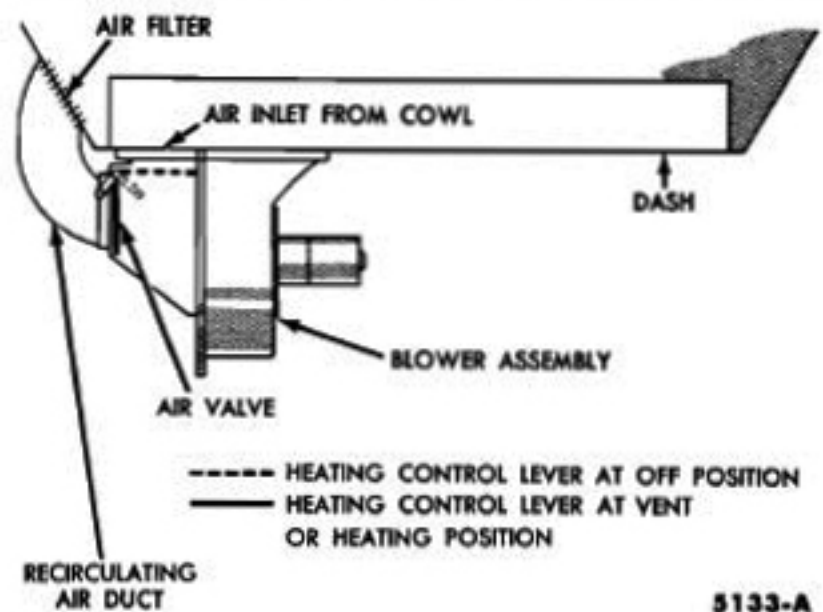

Fig. 20—Blower Assembly Air Valve—Car

1. Move the upper control lever to the LEFT (distance depending upon the degree of cooling desired).
2. Pull the lower LEFT knob OUT, and push the lower RIGHT knob IN. This arrangement permits the blower to circulate passenger compartment air through the evaporator.

For heating action, the controls should be arranged as follows:

1. Move the upper control lever to the RIGHT (distance depending upon the degree of heating desired).
2. Push the lower LEFT knob IN, and pull the lower RIGHT knob OUT. With this arrangement, the blower receives fresh air from the cowl vent and forces it through the heater core to the passenger compartment.

Leaving both lower knobs pushed IN closes off the cowl vent and permits the blower to recirculate passenger compartment air through the heater core.

For defrosting action, the controls are set the same as for heating action except that the center control is moved from the OFF to the DEF position.

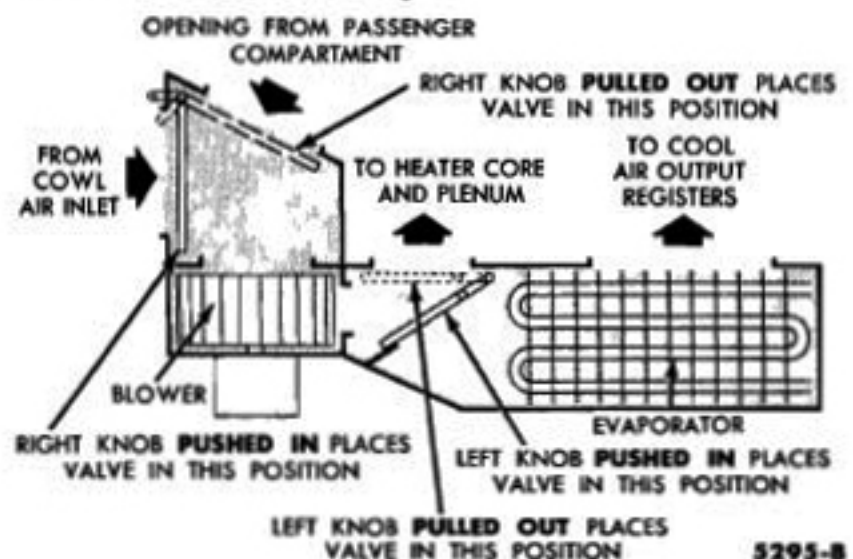

Fig. 21—Select Air Valves—Thunderbird

POLARAIRE. There are two controls for the PolarAire unit, one knob controls the blower motor, the other controls the evaporator thermostat. The motor control knob turns the motor to LO, MED, HI and OFF (Fig. 13). The thermostat knob controls the evaporator temperature between the limits of 28° (MIN) and 63°F. (MAX), through action of the thermostat, which controls the compressor magnetic clutch.

Air Outlet Controls

CAR SELECTAIRE. The car SelectAire air outlets (Fig. 16) are mounted under the lower lip of the instrument

panel. Two control levers direct two streams of air in the direction that the levers point. A door on the bottom of the plenum chamber allows cooled air to be directed to the floor.

THUNDERBIRD SELECTAIRE. The Thunderbird SelectAire air outlets (Fig. 17), are mounted in the center of the instrument panel. Four thumb operated wheels direct two streams of air in various directions.

POLARAIRE. There are five PolarAire air outlets, one on each side of the evaporator case and three on the front of the case (Fig. 18). The adjustable air outlet louvers allow direction of cooled air in various directions.

Maintenance, Trouble Shooting, and Test Procedures

Section	Page
1 Safety Precautions.....	13
2 Maintenance and Adjustments.....	14
3 Trouble Shooting Procedures.....	16
4 Test Procedures.....	18

This chapter gives safety precautions that should be observed when working on a refrigeration system. Main-

tenance, adjustments, trouble shooting, and test procedures are also given.

1. SAFETY PRECAUTIONS

The refrigerant used in the Ford air conditioner systems is Refrigerant-12. Refrigerant-12 is nonexplosive, noninflammable, noncorrosive, has practically no odor, and is heavier than air. Although it is a safe refrigerant, certain precautions must be observed to protect the parts involved and the person who is working on the unit.

CAUTION: *Use only Refrigerant-12 in the Select-Aire and Polar-Aire Conditioners.*

Liquid Refrigerant-12, at normal atmospheric pressures and temperatures, evaporates so quickly that it tends to freeze anything that it contacts. For this reason, extreme care must be taken to prevent any liquid refrigerant from coming in contact with the skin and especially the eyes.

Refrigerant-12 is readily absorbed by most types of oil. It is therefore recommended that a bottle of sterile mineral oil and a quantity of weak boric acid solution be kept nearby when servicing the air conditioning system. Should any liquid refrigerant get into the eyes, use a few drops of mineral oil to wash them out, then wash the eyes clean with the weak boric acid solution. Seek a doctor's aid immediately even though irritation may have ceased.

CAUTION: *Always wear safety goggles when servicing any part of the refrigerating system.*

The Refrigerant-12 in the system is always under pressure. Because the system is tightly sealed, heat applied to any part would cause this pressure to build up excessively.

CAUTION: *To avoid a dangerous explosion, never*

weld, use a blow torch, solder, steam clean, bake body finishes, or use any excessive amount of heat on, or in the immediate area of, any part of the air cooling system or refrigerant supply tank, while they are closed to the atmosphere whether filled with refrigerant or not.

The liquid refrigerant evaporates so rapidly that the resulting refrigerant gas will displace the air surrounding the area where the refrigerant is released. To prevent possible suffocation in enclosed areas, always discharge the refrigerant from an air cooling system into the garage exhaust collector. Always maintain good ventilation surrounding the work area. *If the vehicle is to be undercoated, make certain that the undercoating does not plug the evaporator drain tubes.*

Although Refrigerant-12 gas, under normal conditions, is non poisonous, the discharge of refrigerant gas near an open flame can produce a very poisonous gas. This gas will also attack all bright metal surfaces. This poisonous gas is generated in small quantities when the flame-type leak detector is used. Avoid inhaling the fumes from the leak detector. *Make certain that Refrigerant-12 is both stored and installed in accordance with all state and local ordinances.*

When admitting Refrigerant-12 gas into the cooling unit, always keep the tank in an upright position. If the tank is on its side or upside down, liquid Refrigerant-12 will enter the system and damage the compressor. *In surrounding air temperatures above 90°F., continuous engine idle will result in excessively high compressor pressures.*

2. MAINTENANCE AND ADJUSTMENTS

Maintenance

The amount of Refrigerant-12 in an air cooling system is important if maximum efficiency of the system is to be obtained. Check the Refrigerant-12 at each 1,000 mile period.

A check of the refrigerant may be made by rotating the cover on the liquid sight glass (Fig 4). Observe the refrigerant flow for a minute with the engine running at 1500 rpm, and the cooling control lever at the maximum cooling position. If no bubbles appear in the liquid behind the glass, it may be assumed that there is enough refrigerant in the system, providing that the cooling system is in working order. If bubbles do appear, add Refrigerant-12 to the system until the bubbles disappear, then add an additional one pound of refrigerant.

Check the compressor oil level only if a portion of the refrigerant system is being replaced, or if there was a leak in the system and the refrigerant is being replaced.

Adjustments

Efficient operation of the SelectAire Conditioner is dependent upon proper adjustment of the control cables. Make a check of the adjustment of all controls whenever the evaporator or control panel has been removed or at each 5,000 mile period.

CAR CONTROL CABLE ADJUSTMENT. Set the cooling control lever (top control unit lever, Fig. 13) at its extreme left (OFF) position. With the lever at this position, adjust the cable leading to the thermostatic switch

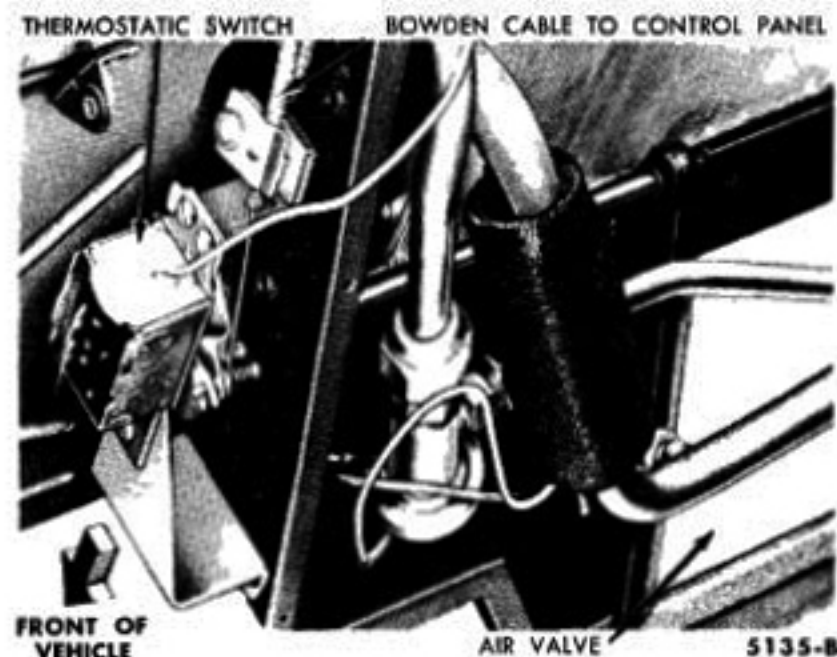

Fig. 22—Thermostatic Switch Cable Adjustment—Car

(Fig. 22) so that the switch is off (switch control lever closest to the dash), and the evaporator air valve closed. The adjustment may be made at either the control panel or at the valve.

Place the HEATING control lever (bottom control unit lever) $\frac{1}{16}$ inch from the left end of the lever slot. Adjust the blower housing air valve to the maximum counter clockwise or outside air OFF position (dashed line position Fig. 20). The adjustment may be made at the blower housing end of the cable.

Place the HEATING control lever in the notch under the VENT position, and adjust the heater thermostat cable on the bottom of the plenum chamber (Fig. 23), so that the heater thermostat is in the closed position (thermostat lever all the way to the right). *The heater thermostat used with the 1958 car air conditioner is the Dole type.*

Place the defroster knob (to the right of the steering column) $\frac{1}{16}$ inch from the all-the-way-in position. Adjust the Bowden cable at the left back of the plenum chamber (Fig. 24), so that the defroster air valve arm is as far to the right as possible and the lip of the valve is in the spring detent. The spring detent holds the air valve in the closed position.

THUNDERBIRD CONTROL CABLE ADJUSTMENT. Place the thermostat control lever at the center OFF position (top lever Fig. 14). With the lever in this position, adjust the cable leading to the thermostatic switch (Fig. 12) so that the switch is off (switch control lever as far forward as possible). At the same time adjust the cable leading to the heater thermostat (Fig. 25), so that the thermostat is in the closed position (thermostat lever all the way to the right). *The heater thermostat used*

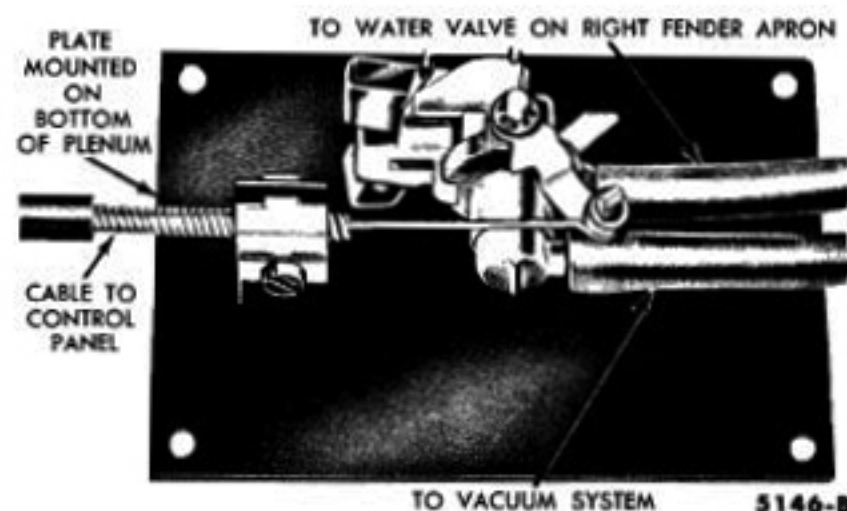

Fig. 23—Heater Thermostat Cable Adjustment—Car

with the 1958 Thunderbird air conditioner is the Ranco type.

Place the middle control lever (Fig. 14) at the center (OFF) position. With the lever in this position, adjust the cable leading to the defroster air valve in the heater plenum, so that the defroster air valve is in the up position (air valve arm as far to the right as possible).

Push the lower left hand control knob IN (Fig. 14). With the knob in this position, adjust the cable leading to the evaporator (blower outlet) air valve (Fig. 12) so that the air valve closes the opening to the evaporator (valve arm as far forward as possible).

Push the lower right hand control knob IN (Fig. 14). With the knob in this position, adjust the cable leading to the cowl air inlet valve (Fig. 26) so that the cowl air inlet valve is closed to the outside air (valve actuating arm as far forward as possible).

COMPRESSOR OIL LEVEL ADJUSTMENT. Under normal conditions, when the air cooling system is operating satisfactorily, the compressor oil level need not be checked. There is no place for the oil to go except inside the sealed system. When the car is first started, some of the oil will be pumped into the rest of the system. After 15 minutes of operation, most of the oil is returned to the compressor crankcase.

Should any portion of the refrigerant system be replaced, or should the refrigerant leak out and be replaced, the oil level should be checked at the time of replacement.

Check the oil after the system has been charged and has been operating at an engine speed of 1500 rpm for 15 minutes in 60°F. surrounding air temperature or above, and with the compressor mounted on the engine.

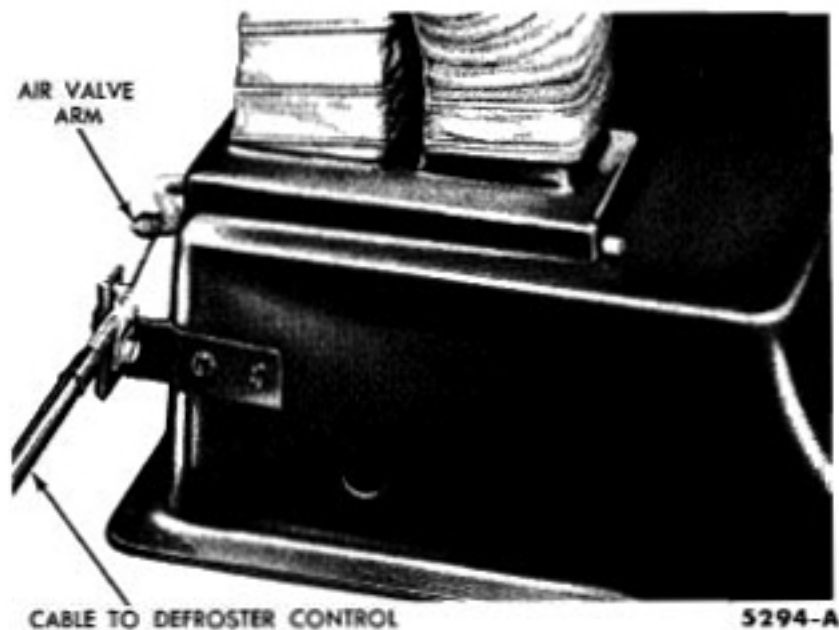

Fig. 24—Defroster Air Valve Adjustment

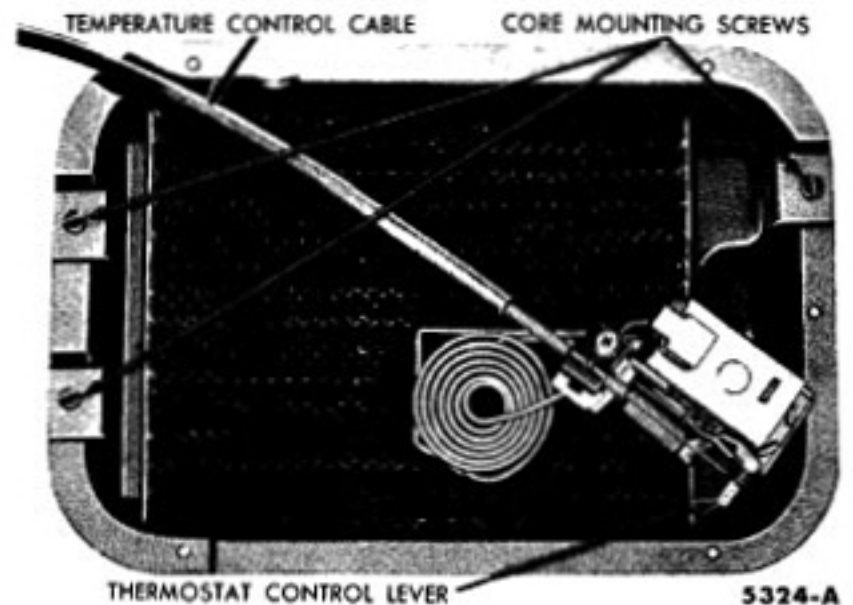

Fig. 25—Heater Thermostat Cable Adjustment—Thunderbird

Turn off the engine, and isolate the compressor. Remove the oil filler plug from the compressor (Figs. 9 or 10), insert a $\frac{1}{8}$ inch diameter rod in the oil filler hole until it bottoms. The rod should show $\frac{3}{4}$ inch of oil. This is equivalent to 9 ounces of oil. If additional oil is needed in the car compressor, add Suniso 4-G refrigerator compressor oil, or equivalent. Add Suniso 5-G oil or equivalent to the Thunderbird compressor. It may be necessary to rotate the compressor crankshaft slightly (by hand) so that the dip rod will clear the crankshaft counter weight.

Replace the oil filler plug, then evacuate and cut the compressor back into the system. Be sure to check the compressor filler opening for leaks.

COMPRESSOR BELT ADJUSTMENT. Proper adjustment of the compressor belt requires fabrication of a

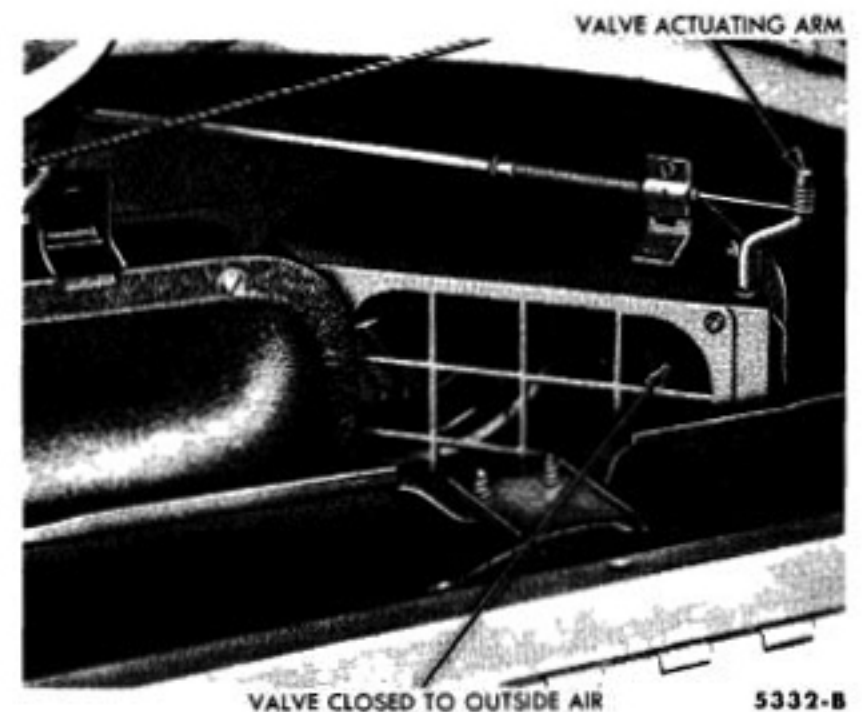

Fig. 26—Cowl Air Inlet Valve Adjustment—Thunderbird

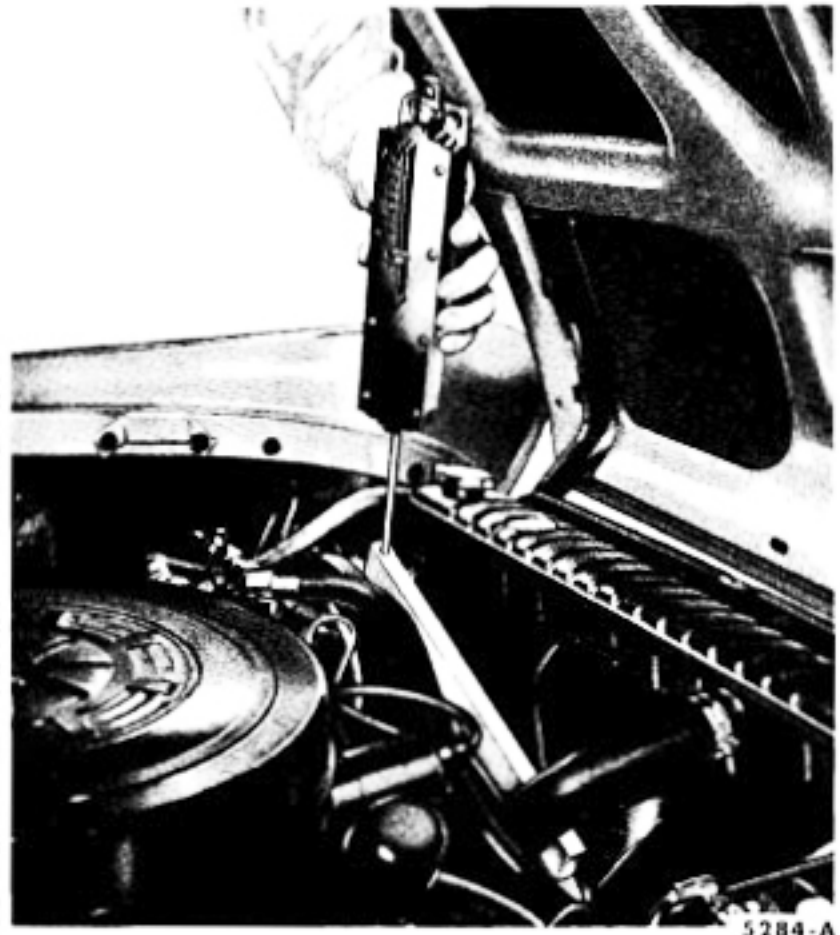
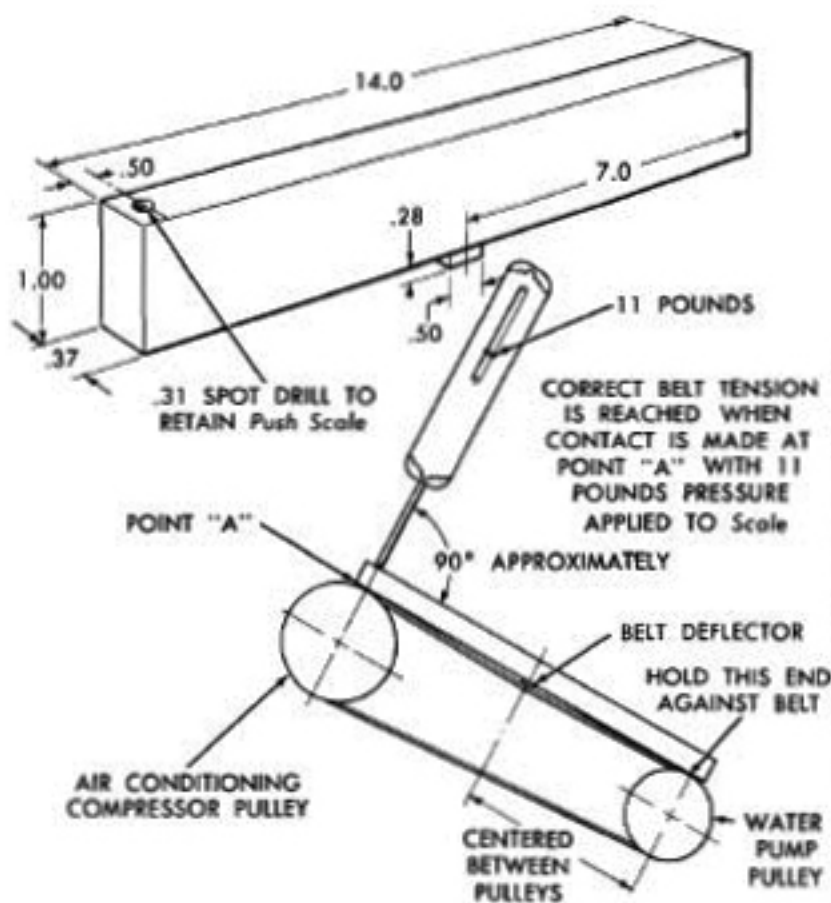

Fig. 27—Compressor Belt Adjustment

special tool to be used in conjunction with a push scale as shown in Fig. 27.

Lay the tool across the two pulleys so that the belt deflector block (on the underside of the tool) is centered between the two pulleys as shown in Fig. 27. While holding the one end of the tool fast against the water pump pulley, force the opposite end down by pressing against the push scale until point "A" contacts the top of the compressor pulley (Fig. 27). The scale should read 11 pounds if the adjustment is correct.

If the reading is less than 11 pounds, the belt has insufficient tension. Loosen the four mounting nuts, slide the compressor toward the outside of the car, then tighten the mounting nuts. Recheck the adjustment with the tool and scale.

If the reading is greater than 11 pounds, the belt has too much tension. Loosen the four mounting nuts, slide the compressor toward the center of the car, then tighten the mounting nuts. Recheck the adjustment with the tool and scale.

3. TROUBLE SHOOTING PROCEDURES

The trouble shooting procedures for the air conditioner have been set up assuming that the test gauges used are accurate and that the manifold valves are in good condition. Figure 28 shows a "road map" to follow when trouble shooting the symptom, "Insufficient or No Cooling." Malfunctions of the system that will not affect the cooling function are listed under the heading "Other System Malfunctions."

Insufficient or No Cooling

First make certain that the evaporator is not clogged with ice because the thermostatic switch feeler tube is not properly contacting the fins. Check to make certain

that all body openings are air tight. Check the adjustment and condition of the compressor belt. Replace the belt if necessary. Make sure that the compressor magnetic clutch is operating properly. Set all controls for maximum cooling, then check the air conditioning system for air output.

SET CONTROLS FOR MAXIMUM COOLING. Before making any of the following checks, all controls should be set for maximum cooling. With the car PolarAire, set the cooling control at MAX (Fig. 15). With the car SelectAire, set the cooling control (upper) lever at maximum cooling and the heating control (lower) lever at the OFF position (Fig. 13). With the Thunderbird, set

the upper control lever to the maximum cooling (extreme left) position, pull the lower LEFT knob OUT, and push the lower RIGHT knob IN (Fig. 14).

On all three systems, set the blower motor at high.

CHECK SYSTEM AIR OUTPUT. If the air output appears less than normal, check the air passages, including the evaporator, for dirt and obstructions. Clean where necessary. Make certain that the evaporator and blower air valves are adjusted properly. Check the blower motor for proper operation. Normal current draw for the high speed winding is 10 amperes at 12-12.5 volts. The slow speed winding current draw is 5 amperes at 12-12.5 volts. If the current drawn by the motor, is not to specifications, remove the motor, determine the cause, and repair or replace the motor as required. Make certain that the voltage regulator is properly set to give full voltage to the blower. Check the two service valves, and make sure that both valves are at the maximum counterclockwise position.

CHECK THE SIGHT GLASS FOR BUBBLES. If the preceding steps do not cure the trouble, check the sight glass for bubbles. Run the engine at 1500 rpm with the cooling control lever set for maximum cooling, and the blower on high. Bubbles in the sight glass indicate an undercharge of refrigerant. Check the system for leaks, repair if necessary and charge the system with the proper amount of Refrigerant-12.

No bubbles in the sight glass will indicate either a full charge or a complete loss of refrigerant. To determine if there is refrigerant in the system, run the engine at 1500 rpm, and set the cooling control lever at the maximum cooling position. Open the high pressure service valve slightly. Allow the gas to escape through the gauge port slowly, observing the sight glass. If bubbles begin to appear, close the high pressure service valve, and make a partial charge of one pound of Refrigerant-12. The system will then have a complete charge. If no bubbles appear, check for refrigerant leaks, repair the breaks if necessary, and charge the system with the proper amount of Refrigerant-12.

CHECK THE SYSTEM PRESSURES. If no bubbles are seen in the sight glass after several minutes of operation, and a full refrigerant charge is evident, check the high and low pressures. Depending on the surrounding air temperatures, the high and low pressures should show an approximate differential pressure ratio of 6 or 7 to 1. The low pressure will be from 16-25 pounds, and the high pressure will be from 100-180 pounds at a surrounding air temperature of 75°F. Check the system pressures with the engine at 1500 rpm, all controls set for maximum cooling, and the front of the car at least 5 feet from any wall. At idle speed and a

surrounding air temperature of 100°-110°F., the high pressure may go as high as 300 pounds.

LOW PRESSURE BELOW NORMAL, HIGH PRESSURE NORMAL. These pressures indicate a restriction between the receiver and the expansion valve or between the expansion valve and the low pressure service valve. If the low pressure is actually a vacuum, the expansion valve is probably closed tightly. Shut the system down and allow it to warm to room temperature. Start the engine and if the evaporator will now become cool, the expansion valve was frozen because of moisture in the system. Release the refrigerant, replace the dryer-receiver assembly, check for leaks, then charge the system.

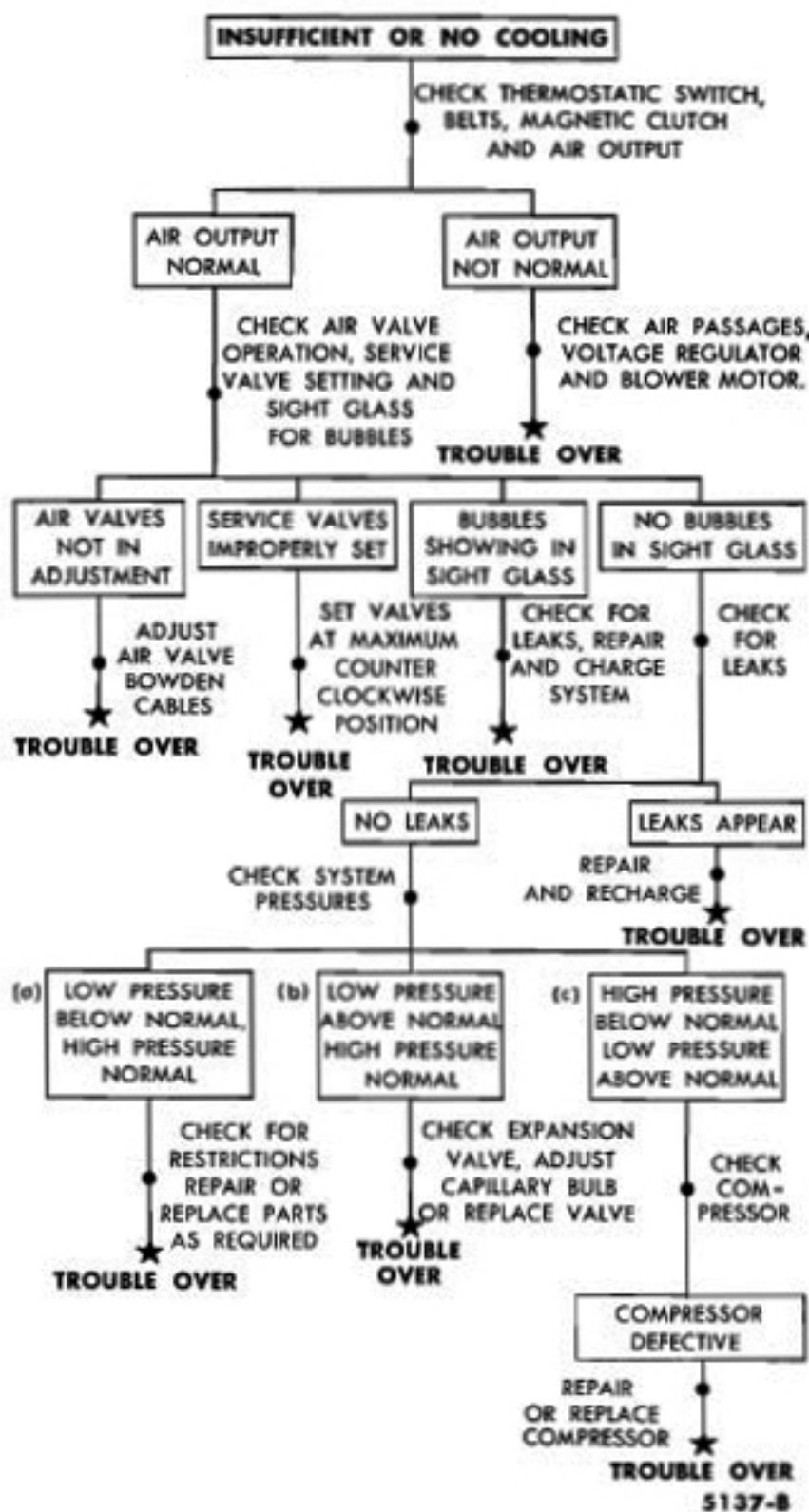

Fig. 28—Insufficient or No Cooling "Road Map"

Check the system between the receiver outlet and the low pressure service valve for restrictions, by feeling all of the connections and components. Any portion that is cold to the touch or that frosts up, with the pressures as indicated here, is restricting the refrigerant flow.

LOW PRESSURE ABOVE NORMAL, HIGH PRESSURE NORMAL. Observe both pressure gauges. If the low pressure is above normal (16-25 pounds at 75°F.) and the high pressure is at or near normal (100-180 pounds at 75°F.) the expansion valve is not operating properly. This condition may cause the compressor to receive slugs of liquid and thus to be very noisy. Also, the suction side of the compressor and the crankcase and head will be colder than normal and will "frost up."

The expansion valve will allow too much liquid refrigerant to flow to the compressor if it is defective or, if the temperature sensing bulb is not making close contact with the evaporator outlet pipe. Make sure that the bulb is properly clipped to the outlet pipe, and properly covered. Remove the expansion valve and make an expansion valve test. Clean the valve orifice or replace the valve as required.

HIGH PRESSURE BELOW NORMAL, LOW PRESSURE ABOVE NORMAL. If the two pressures are equal within

30 pounds of each other, the compressor may be defective. Check the compressor volumetric efficiency. Repair or replace the compressor as needed.

Other System Malfunctions

Besides "Insufficient Cooling," other system malfunctions that are not readily apparent, may affect the system if left unchecked.

HIGH PRESSURE ABOVE NORMAL. High compressor head pressures are caused by an overcharge of refrigerant, air in the system, condenser air passages clogged, a restriction between the condenser inlet and the receiver, or high surrounding air temperatures. High head pressures are generally evidenced by a noisy compressor. Bleeding the system will relieve both an overcharge of refrigerant and entrapped air.

NOTE: *Whenever the system has been opened three times the receiver dryer should be replaced as a precaution against icing of the distributor tubes.*

POOR TEMPERATURE CONTROL. If cooling is obtained only when all the controls are set at the maximum cooling position, check the heater water valve. Make certain that the valve is not stuck in the open position, and that the control cable is properly adjusted.

4. TEST PROCEDURES

To perform the test procedures, a test manifold and gauge set with connecting hoses, a refrigeration ratchet wrench, a tank of Refrigerant-12 (50 pound tank) a suitable scale for weighing the Refrigerant-12 tank, a leak detector, a thermometer, a plug and cap set, and safety goggles are required.

CAUTION: *Before making any tests or working*

on the air conditioning system, be sure to read the safety precautions given in this manual.

Manifold Gauge Set Installation

Remove the service valve stem covers and make sure that both service valves are at the maximum counter-clockwise position (Fig. 29). Remove the service valve gauge port covers, and attach the flexible hoses to the gauge ports, to a vacuum pump and to a tank of Refrigerant-12 (Fig. 30). Turn both manifold gauge valves to the maximum clockwise position (Fig. 31) and close the vacuum pump valve. *The manifold valves are so arranged that when they are in the maximum clockwise or closed position, the center manifold connection is shut-off from the gauges, but the gauges continue to read the pressures in their respective hoses.*

Checking for Leaks

Attach the manifold gauge set (Fig. 30). Leave both manifold gauge valves at the maximum clockwise position (Fig. 31). Set both service valves at the center

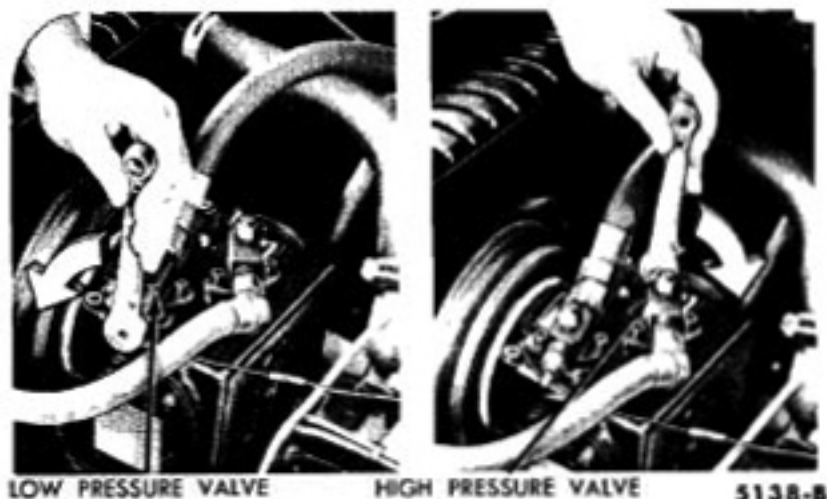

Fig. 29—Closing Service Valve Gauge Ports

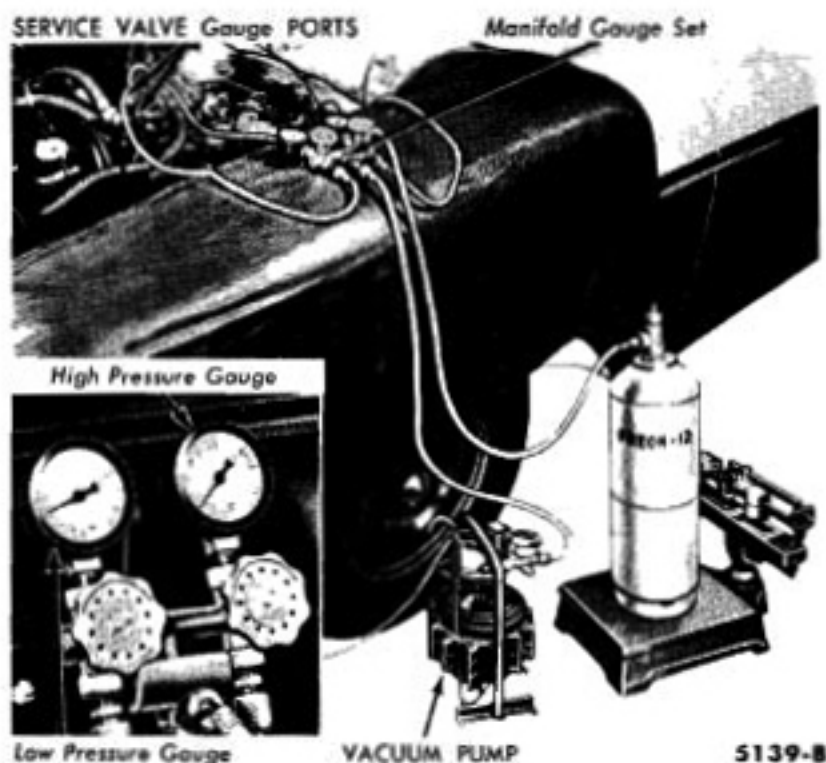

Fig. 30—Manifold Gauge Set Attached to System

position. Both gauges should now show approximately 60 to 80 pounds pressure at 75°F. If very little or no pressure is indicated, leave the vacuum pump valve closed, open the Refrigerant-12 tank valve, and set the low pressure manifold gauge valve to the counterclockwise position. This opens the system to tank pressure. Check all connections, and the compressor shaft seal for leaks, using a flame type leak detector (Fig. 32). Follow the directions with the leak detector. The smaller the flame the more sensitive it is to leaks. Therefore, to insure accurate leak indication keep the flame as small as possible. Hold the open end of the hose at each suspected

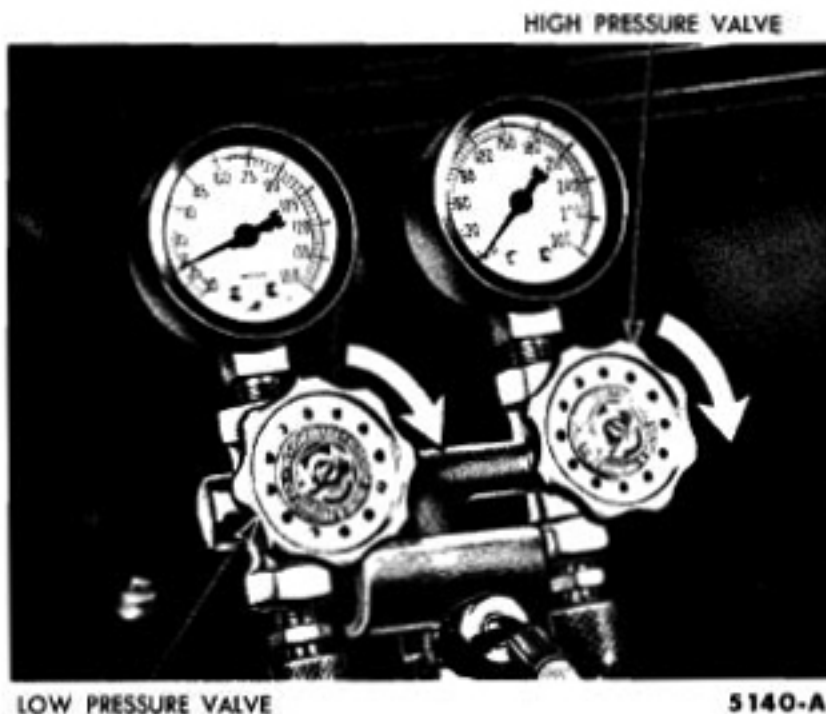

Fig. 31—Closing Manifold Valves



Fig. 32—Using Leak Detector

leak point for two or three seconds. The flame will normally be almost colorless. The slightest leak will be indicated by a bright color to the flame. Be sure to check the manifold gauge set and hoses for leaks as well as the rest of the system.

CAUTION: *If the surrounding air is permeated with refrigerant gas, the leak detector will indicate this gas all the time. Good ventilation is necessary to prevent this situation. A fan, even in a well ventilated area, is very helpful in removing small traces of refrigerant vapor.*

Discharging the System

Discharge the refrigerant from the system before replacing any part of the system, except the compressor.

To discharge the system, connect the manifold gauge set to the system (Fig. 30). Do not connect the manifold center connection hoses to the Refrigerant-12 tank,

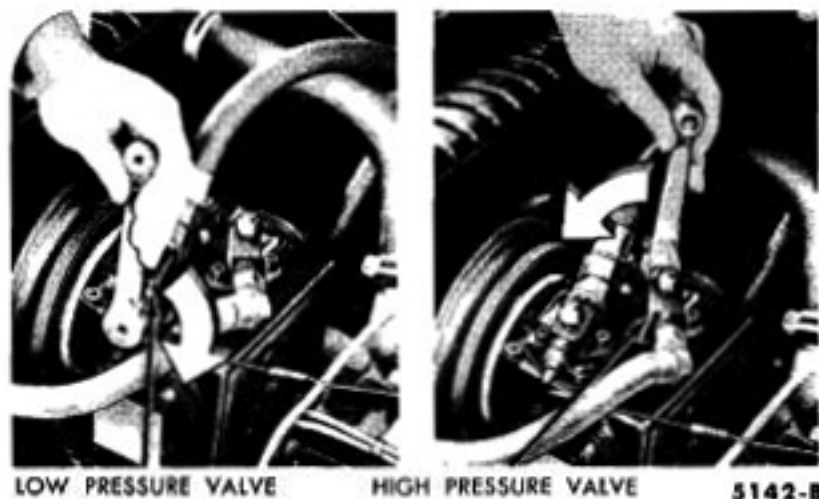

Fig. 33—Opening Service Valve Gauge Ports

or vacuum pump. Place the open end of these hoses in a garage exhaust outlet. Set the high pressure manifold gauge valve at the maximum counterclockwise or open position. Open the high pressure service valve a slight amount (Fig. 33), and allow the refrigerant to discharge slowly from the system.

CAUTION: *Do not allow the refrigerant to rush out, as the oil in the compressor will be forced out along with it.*

Charging the System

The procedure for charging depends on whether a partial charge or a complete charge is being made. When a complete charge is to be made, check for leaks first, then release the pressure and evacuate the system.

EVACUATING THE SYSTEM. Attach the manifold gauge set, a tank of Refrigerant-12 and a vacuum pump to the system (Fig. 30). Make certain that the Refrigerant-12 tank valve is tightly closed. Set both service valves to the mid-position. Open both manifold valves (Fig. 34). Release any pressure in the system. Open the vacuum pump valve and run the pump until the low pressure gauge reads at least 25 inches, and as close to 30 inches of vacuum as possible. Continue vacuum pump operation for 20 to 30 minutes to boil any moisture out of the system. Close the pump valve. Turn off the pump.

MAKING A PARTIAL CHARGE. Attach the manifold gauge set (Fig. 30). Open both manifold valves (Fig. 34). Close the vacuum pump valve. Open the Refrigerant-12 tank valve. Purge the air from the high pressure hose by loosening the high pressure hose at the service valve, for a few seconds. Tighten the connections and set the high pressure manifold gauge valve at the maximum

clockwise position. Loosen the low pressure gauge hose slightly at the low pressure service valve, for a few seconds, to purge the air from the hose. Tighten the connection. Set both service valves at the center position.

Run the engine at 1500 rpm with all controls at the maximum cold position. Charge the system until all bubbles disappear from the sight glass then add one additional pound of Refrigerant-12. Shut the Refrigerant-12 tank valve.

It may be necessary to place the Refrigerant-12 tank in a container of hot water at about 150°F. to force the gas from the tank during charging.

CAUTION: *Never heat the Refrigerant-12 tank with a torch. A dangerous explosion may result.*

Set both service valves at the maximum counterclockwise position (Fig. 29). Remove the gauge set, and cap the service valve gauge ports and valve stems.

MAKING A COMPLETE CHARGE. Evacuate the system first. Leave both service valves at the midposition and the vacuum pump valve closed. Leave the low pressure manifold gauge valve at the maximum counterclockwise or open position (Fig. 34). Set the high pressure manifold gauge valve at the maximum clockwise or closed position (Fig. 31). Set all controls to the maximum cold position.

Open the Refrigerant-12 tank valve. Run the engine at 1500 rpm. Weigh 3½ pounds of Refrigerant-12 into the system. During the charging, the high pressure may build up to an excessive value. This can be caused by an overcharge of refrigerant, an overheated engine or air in the system, in combination with high surrounding temperatures. Never allow the high pressure to exceed 240 pounds. Stop the engine, determine the cause, and correct it.

When the proper charge has entered the system, no bubbles will be seen in the sight glass. The bubbles will begin to disappear when approximately 2½ pounds of refrigerant are in the system. After the proper charge has been made, close the Refrigerant-12 tank valve, and check the system pressures for proper operation. Set both service valves at the maximum counterclockwise position (Fig. 29). Remove the gauge set, and cap the service valve gauge ports and valve stems.

Checking System Pressures

The pressures developed on the high pressure and low pressure side of the compressor indicate whether or not the system is operating properly.

SYSTEM PRESSURES. Attach the manifold gauge set (Fig. 30). It will not be necessary to attach the Refrigerant-12 tank unless refrigerant is to be added to the system. Set both manifold gauge valves at the maximum clockwise, or closed, position (Fig. 31). Set both service valves at the center position. Run the engine at 1500

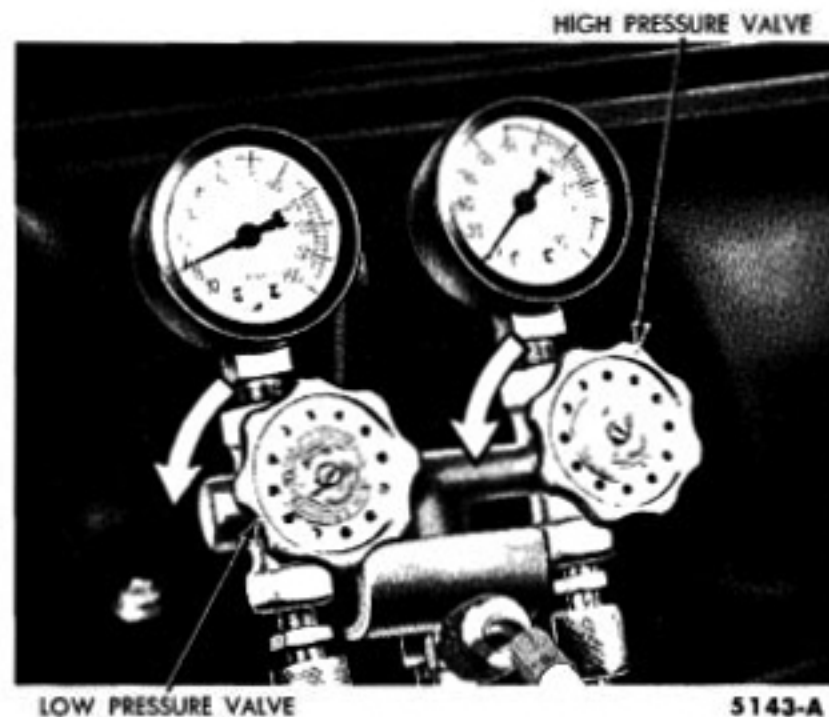

Fig. 34—Opening Manifold Valves

rpm. Set all controls at the maximum cooling position. The actual pressures indicated on the gauges will depend on the temperature of the surrounding air and the humidity. Higher air temperatures along with low humidity, will give higher system pressures. The figures given are for an ambient (surrounding air) temperature of 75°F. For every 10°F. increase in ambient air temperature, the pressures will increase approximately 20 pounds.

The low pressure gauge should indicate a pressure of from 16-25 pounds at 75°F. The high pressure gauge should indicate a pressure of from 100-180 pounds at 75°. *With the engine at idle speed and the surrounding air temperature at 110°F., the above figures will not be true. High pressures of 300 pounds may be obtained under these severe conditions.*

BLEEDING AIR FROM THE SYSTEM. Air trapped in the system will cause the high pressure to build up excessively. This air may be removed from the system by bleeding.

Attach the manifold gauge set to the system (Fig. 30). Set both service valves at the center position. Run the engine at 1500 rpm with all controls at the maximum cold position. If air is trapped in the system, the high pressure may exceed 200 pounds, depending on the surrounding air temperature and the amount of air in the system.

Turn the engine off. Let the system stand for 10 or 15 minutes to allow the air to collect at the high pressure service valve. Loosen the high pressure gauge hose at the high pressure service valve slightly, and allow the gas and air to escape for 5-10 seconds. Tighten the connection, start the car, and check the pressure again. Repeat the procedure if necessary. After bleeding, check the liquid sight glass to make certain that too much refrigerant was not removed. Put a partial charge in the system if necessary.

COMPRESSOR VOLUMETRIC EFFICIENCY TEST. Malfunction of the compressor can be isolated by checking the compressor volumetric efficiency with a special tool. Make the test with the car in a clean dry atmosphere.

Run the engine at 1500 rpm with all controls at maximum cooling for at least 10 minutes. Adjust the engine idle with a tachometer to exactly 515 rpm with the compressor clutch engaged. Turn the engine off and set the cooling control to the OFF position. Isolate the compressor, then remove both high and low pressure service valve gauge port caps, allowing the gas in the compressor to escape.

Attach the special tool (calibrated orifice with gauge attached) to the high pressure service valve gauge port (Fig. 35). Start the engine. Engage the magnetic clutch for 15 second intervals, by moving the cooling control from the OFF position to the maximum cooling position,

and observe the maximum gauge pressure at the end of each 15 second interval. *Be sure to allow the gauge pressure to drop to zero between the 15 second intervals.* Stop the engine.

A good compressor will bring the pressure to 200 psi in 15 seconds. If the pressure does not come up to 200 psi, in 15 seconds, clean the compressor intake screen. If the intake screen is clean, remove and inspect the valve plate. Most of the failures to come up to the 200 psi specification will be caused by small foreign particles under the valve plate leaves or a defective valve plate. Clean the valve plate and assemble it to the compressor using new gaskets. If this does not effect a cure, replace the valve plate or the compressor as required.

If no further work is to be done on the system after making the volumetric efficiency test, disconnect the orifice tool and gauge, evacuate the compressor and connect it back into the system.

Checking System Temperatures

A good indication may be had of overall cooling system operation by measuring the outlet air temperature.

Set all controls for maximum cooling. Place the stem of the thermometer through the right outlet air vent as far as it will go. Run the engine at 1500 rpm. Turn the blower switch to high.

The thermometer should indicate a temperature of approximately 40°F. with a room temperature of 75°F. and a relative humidity of 50%. The outlet air temperature should be about 35° below the surrounding air

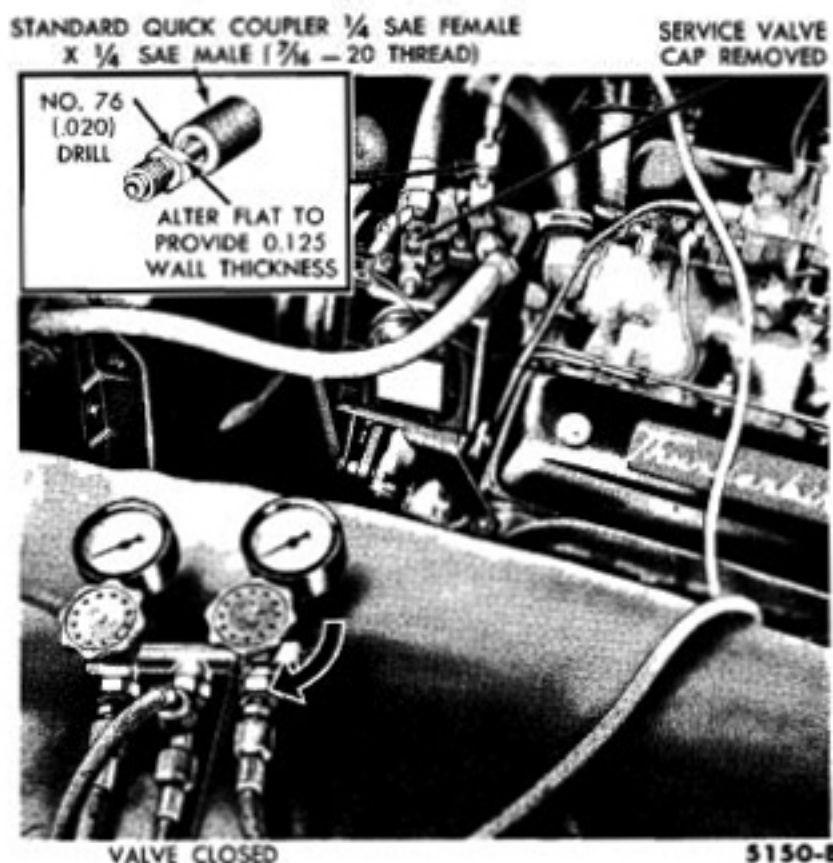

Fig. 35—Compressor Volumetric Efficiency Test

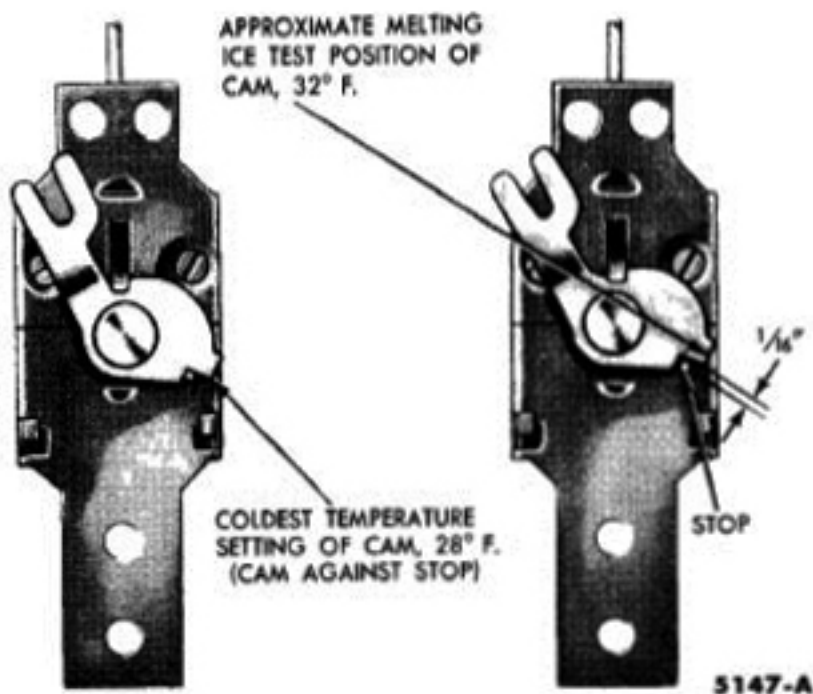

Fig. 36—Thermostatic Switch Cam Test Positions

temperature with 50% relative humidity. In case the humidity is higher than 50% the temperature differential will be somewhat less. If the humidity is less than

50% the outlet air temperature will approach closer to the evaporator temperature setting of 32°F.

Thermostatic Switch Test

The switch must be removed from the evaporator for this test. Set the switch cam at the coldest temperature setting (Fig. 36). Place the sensing tube in a container filled with finely crushed ice and water (32°F.). If the switch clicks, it is defective and should be replaced. If the switch does not click, leave the sensing tube in the ice and turn the cam counterclockwise until a click is heard. The cam should move approximately $\frac{1}{16}$ inch from the cold setting stop (Fig. 36), which represents the 32°F. setting, or the temperature of the melting ice.

With the sensing tube still in the ice, turn the cam back to the cold temperature setting. If the switch clicks it is defective and should be replaced. If the switch does not click, remove the unit from the ice and expose the sensing tube to the air (approximately 75°F.). The switch should click almost immediately after removal from the ice. If it takes longer than 5 or 6 seconds for the switch to click, it is defective and should be replaced.

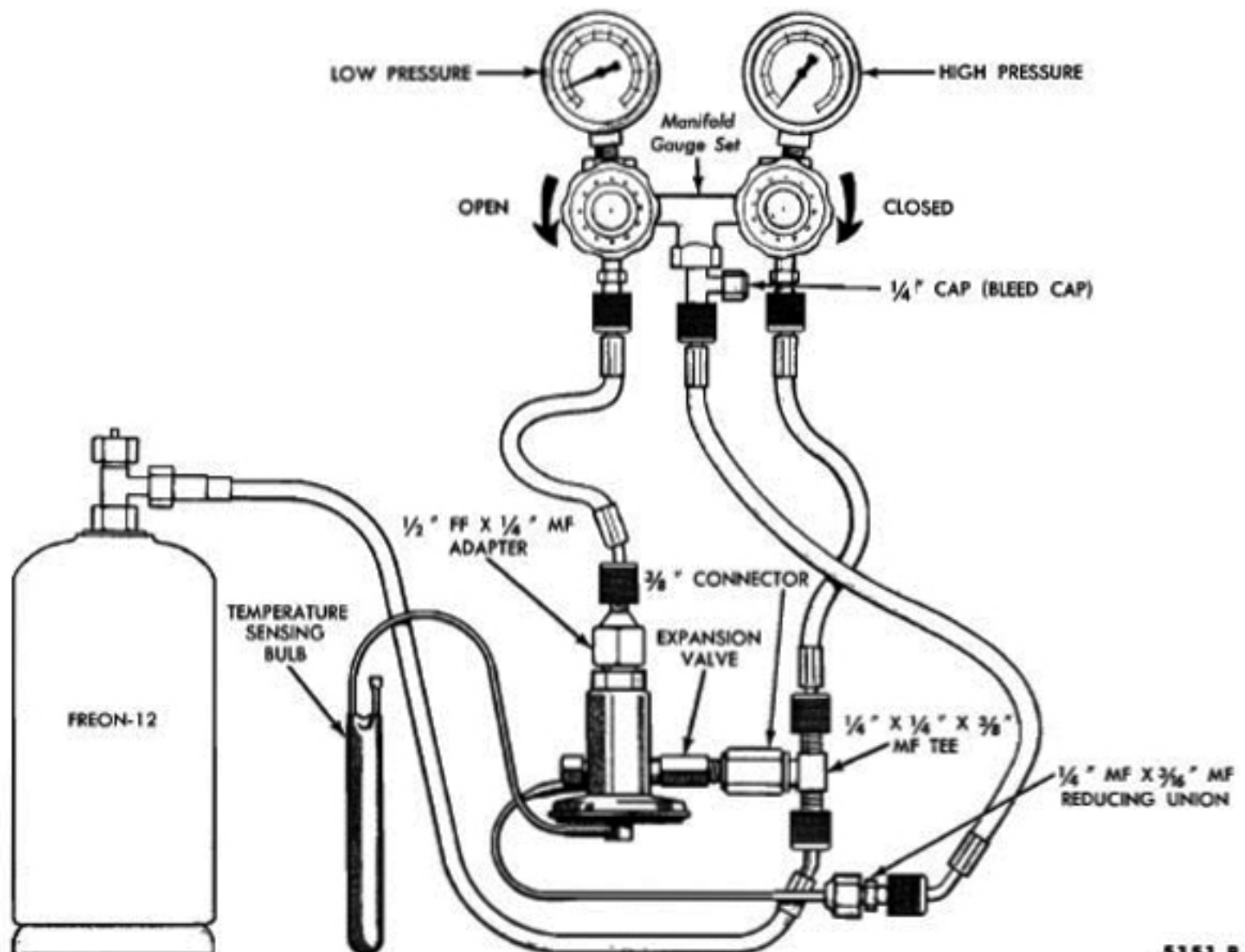

Fig. 37—Expansion Valve Test

Air temperatures more or less than 75°F. will cause the switch to click sooner or later respectively. A known good thermostatic switch can be used as a comparison.

Expansion Valve Tests

Remove the expansion valve from the evaporator and make the test set up as shown in Fig. 37. The high pressure gauge reads tank pressure and the low pressure gauge reads the expansion valve outlet pressure.

PRESSURE LIMIT TEST. Leave the temperature feeler bulb at air temperature and open the Refrigerant-12 tank valve. Observe the pressure at which the needle of the low pressure gauge stops rising or slows abruptly. There should be a minimum of 60 psi on the low pressure side (tank pressure should be 60 psi or higher).

If the low pressure gauge reads zero, there is a dead temperature feeler bulb or a plugged orifice. If the low pressure gauge reads low, the temperature feeler bulb has partially lost its charge or the valve adjustment is improperly set.

ADJUSTMENT TEST. Immerse the temperature feeler bulb in crushed melting ice (32°F.). If all the low pressure joints are tight, the low pressure will not drop. If

necessary use a leak detector to find any leaks. Open the bleed cap slightly and allow the low pressure to drop. Then alternately close and open the bleed cap several times and note the low pressure with the bleed cap open slightly.

The low pressure gauge (with the bleed cap open) should be 24.5 pounds \pm 1.5 pounds. This is a factory adjustment. If the valve does not meet this test, the valve is defective. It cannot be adjusted.

NEEDLE TIGHTNESS TEST. Leave the temperature feeler bulb in the crushed ice (32°F.), and close the bleed cap. The low pressure for a good valve will increase a few pounds and then either stop or build up very slowly. A leaking valve will cause the low pressure to build up rapidly until it equals the inlet pressure. Small pieces of dirt or metal particles in the needle orifice will cause a leaking valve.

Electrical Unit Current Draw

The current drawn by the various electrical units of the air conditioner at a voltage of 12 volts, is as follows:

Blower	{ Hi	10 amperes
	{ Low	5 amperes
Magnetic Clutch	1.8 amperes

Unit Replacement

Section	Page
1 Heater, Evaporator, and Related Parts	24
2 Condenser and Receiver	29
3 Compressor Service	30

Possible malfunction, of the various units that comprise the air conditioning system, is determined by trouble shooting and test procedures presented in previous chapters. With the exception of the compressor, replacement rather than repair of the individual unit is always recommended. In the case of the compressor, replacement kits for certain components are available. When the use of such kits is unable to eliminate the trouble, the compressor must be replaced. This chapter presents detailed removal and installation procedures for each unit and for the compressor replacement kits.

Replacement of the blower and motor assembly, the compressor, or the thermostatic switch can be effected without losing the refrigerant.

Replacement, of all other units or lines in the system, requires complete discharge of refrigerant before removal, and recharge after installation.

When any part of the refrigerant circuit is broken for service operation, install a new metal gasket in any fitting when the fitting mating surfaces are scored. Use of an old gasket or no gasket, when the mating surfaces are scored, may cause refrigerant leakage.

1. HEATER, EVAPORATOR, AND RELATED PARTS

Blower and Motor Assembly— Car PolarAire

Dismount the evaporator. It is not necessary to disconnect the refrigerant hoses. Remove the control knobs, the four evaporator cover mounting screws, and slide the evaporator cover off of the evaporator. Remove the top cover plate. Remove two screws from one side of the fan guard screen and bend the screen out of the way (Fig. 38). Remove the fan from the motor shaft, disconnect the motor wire from the switch, loosen the motor clamp screws, and remove the motor.

The blower motor and fan installation is shown in

Fig. 39. Make certain that the fan blades clear the housing and guard screen when installing the new motor, and that the motor ground wire is firmly attached. Replace the top cover plate, evaporator cover, and control knobs. Mount the evaporator assembly.

Blower and Motor Assembly— Car SelectAire

BLOWER AND MOTOR. Disconnect the three leads from the blower motor. Remove the motor ventilating tube. Remove the four motor mounting screws and re-

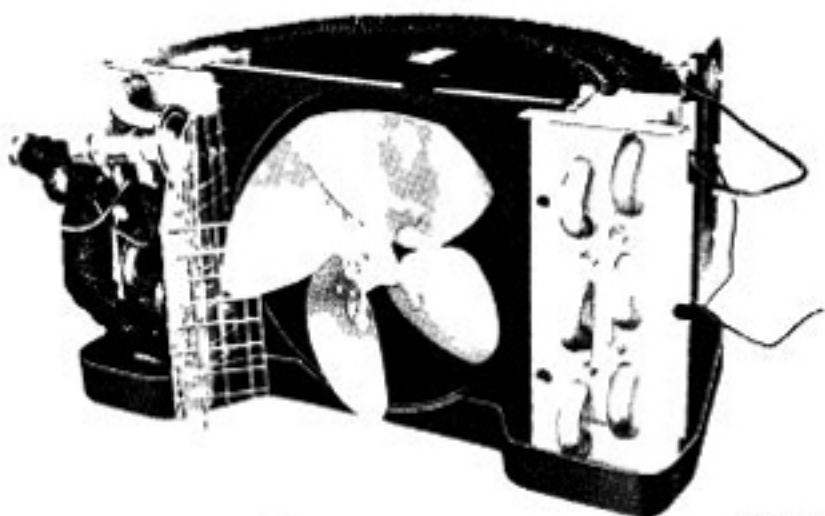

5252-B

Fig. 38—Blower Motor Removal—PolarAire

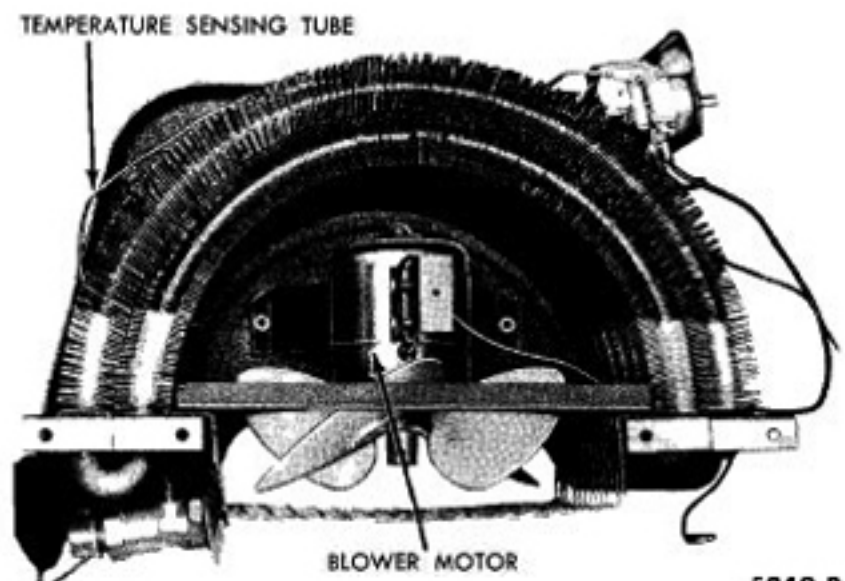

5249-B

Fig. 39—Blower Motor Mounting—PolarAire

move the motor, blower and heat shield from the blower assembly (Fig. 40).

Loosen the set screw, and remove the blower cage from the motor shaft. Remove the nuts from the two motor through bolts, and remove the motor from the mounting plate.

Attach the replacement motor and gasket to the mounting plate with the two through bolts and nuts. Assemble the blower cage to the motor shaft and tighten the set screw. Install the blower motor mounting plate, gasket, and heat shield to the blower housing (Fig. 40). Install the motor ventilating tube and connect the three motor leads. Check the blower operation.

BLOWER HOUSING. Remove the three screws, that attach the bottom of the blower housing to the dash, from inside the passenger compartment. In the engine compartment, remove the blower air valve control cable and disconnect the three motor wires. Remove the three blower housing top mounting screws, move the blower housing away from the dash and disconnect the recirculating air duct from the housing. Remove the blower housing assembly from the vehicle.

When installing the blower housing assembly, connect the recirculating air duct to the blower housing first. Mount the housing to the dash with the three top screws finger tight. From the passenger compartment install the three screws that attach the lower part of the blower housing to the dash then tighten the three top engine compartment screws. Connect the blower air valve control cable, and the blower motor wires.

Blower and Motor Assembly— Thunderbird SelectAire

Disconnect the three motor leads, remove the four blower mounting screws (Fig. 41), and remove the motor and blower assembly. Remove the fan from the motor shaft and remove the motor from the mounting plate.

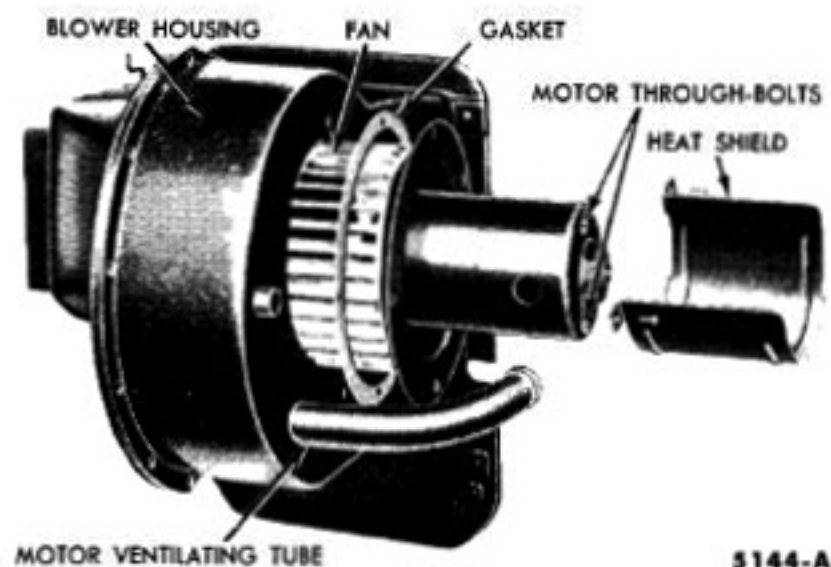

Fig. 40—Blower Motor and Housing Assembly—Car

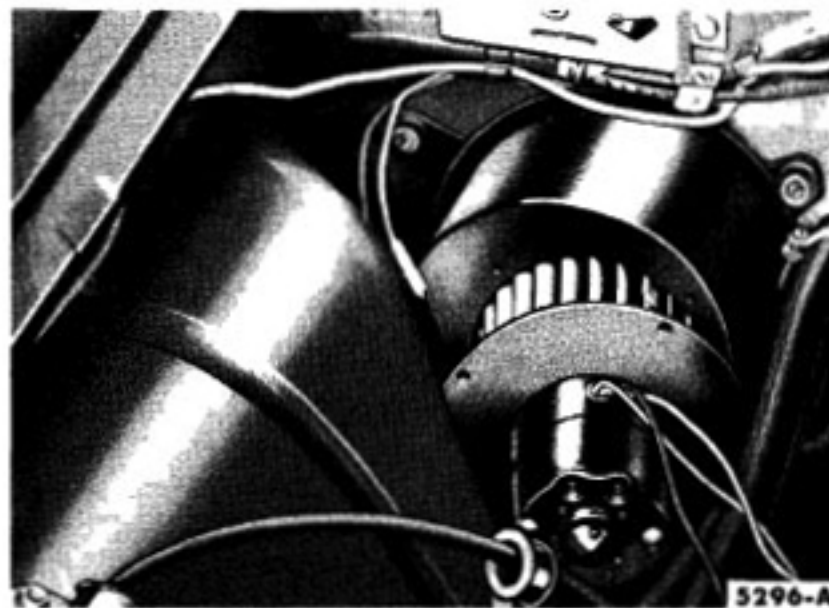

Fig. 41—Blower Motor Removal—Thunderbird

When replacing a blower motor, make certain that the fan turns freely in the housing and that the motor ground wire makes good contact at its mounting point.

Thermostatic Switch

CAR POLARAIRE. To remove the PolarAire Thermostatic switch, remove the evaporator cover mounting screws, remove the control knobs and slide the cover from the assembly (Fig. 42).

Disconnect the wires from the switch. Remove the temperature sensing tube from the evaporator core. Remove the switch mounting screws and remove the switch.

When installing a new thermostatic switch, make certain that the temperature sensing tube is placed in the clip at the front lip of the base (Fig. 42), and that the end of the tube goes all the way through the cooling fins on the right side of the evaporator and makes good contact with the fins.

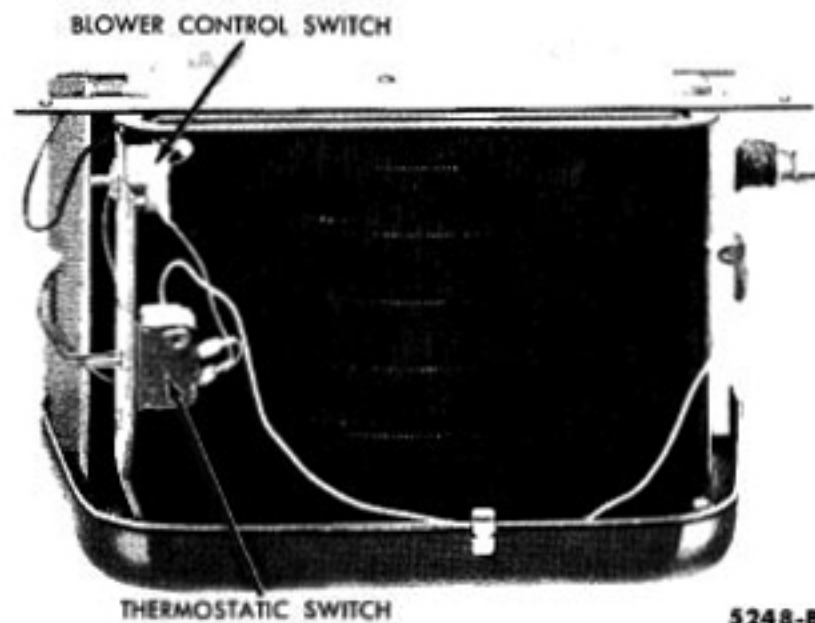

Fig. 42—Thermostatic Switch Replacement—PolarAire

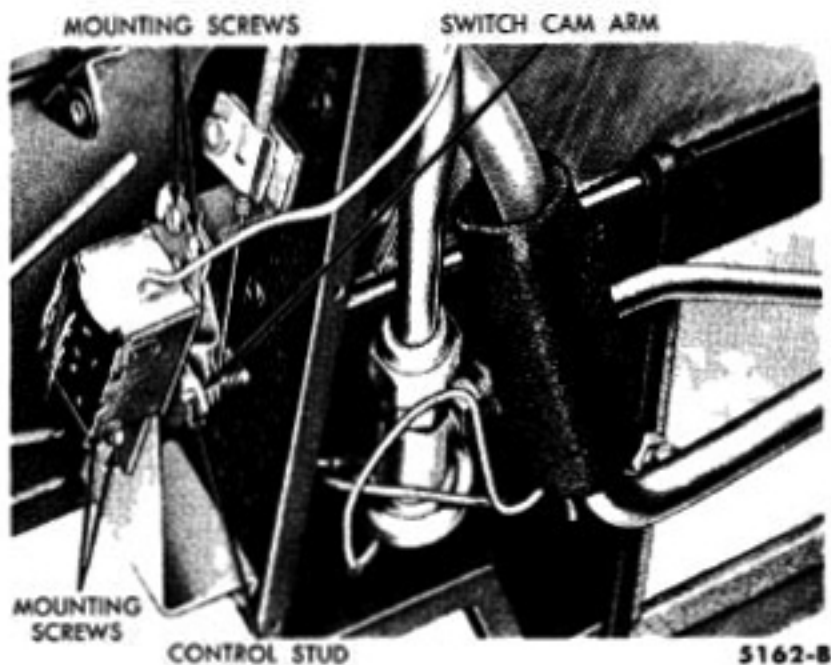

Fig. 43—Thermostatic Switch Mounting—Car

CAR SELECTAIRE. The car SelectAire thermostatic switch can be removed without removing the evaporator. Remove the glove box, remove the sensing tube from the evaporator fins, and remove the wires from the switch. Remove the four mounting screws (Fig. 43), and remove the switch from the evaporator.

Position the replacement switch cam arm so that the arm engages the control stud (Fig. 43) and install the four mounting screws. Route the sensing tube along the side and front of the evaporator housing and shove $7\frac{1}{2}$ inches of the tube through the hole in the front of the evaporator (Fig. 8). Install the sensing tube clamp.

Make certain that the thermostatic switch control cable is properly adjusted. Connect the wires to the switch and install the glove box.

THUNDERBIRD SELECTAIRE. The Thunderbird thermostatic switch is mounted on the right end of the evaporator case, which is in the engine compartment

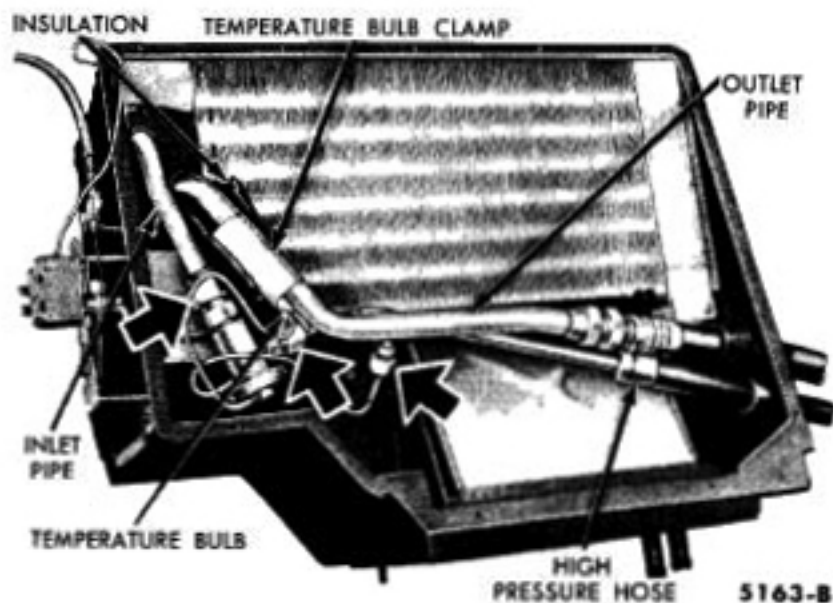

Fig. 44—Evaporator Connections—Car

(Fig. 12). Disconnect the wires and the Bowden cable from the switch. Remove the two mounting screws. Remove the clips and screws from along the top and sides of the evaporator cover. Pry the cover from the case far enough to remove the switch sensing tube from the evaporator.

Insert the sensing tube of the new switch between the evaporator fins and position the tube so that it comes out of the case at the slot in the cover (Fig. 12). Install the cover mounting clips and screws. Mount the switch to the cover, and attach and adjust the Bowden cable and install the thermostat wires.

Expansion Valve

Before replacing an expansion valve, discharge the refrigerant from the system. On the car SelectAire unit, the removal work can be performed from underneath the evaporator. On both the Thunderbird and Polar-Aire units, the evaporator and housing assembly must first be removed from the vehicle. After the new valve is installed, charge the system with refrigerant.

REMOVAL. Remove the evaporator cover. Carefully slit the insulation that covers the temperature bulb and remove the insulation (Figs. 44, 45, or 46). Remove the temperature bulb clamp. Disconnect the expansion valve at the three fittings indicated by the large arrows (Figs. 44, 45, or 46). When disconnecting the valve from the evaporator connections, always use two wrenches in order not to put excessive pressure on the pipe connections.

INSTALLATION. Place the new valve into position and connect it to the three fittings indicated by the large arrows (Figs. 44, 45, or 46). Clamp the temperature

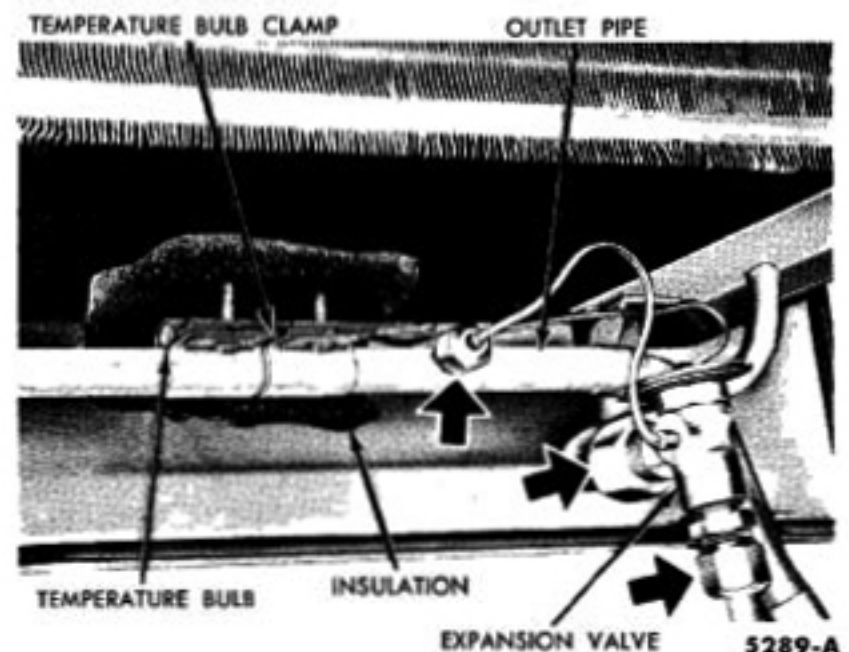

Fig. 45—Evaporator Connections—Thunderbird

bulb to the outlet pipe, and cover the bulb and pipe with the insulation.

Check for leaks, evacuate and charge the system. If the cover gasket was damaged, cement a new gasket into position and install the cover. Install the evaporator on the Thunderbird and PolarAire units.

Heater Core

The heaters used with the PolarAire unit and with the Thunderbird SelectAire unit are separate from the evaporator assembly. Follow the regular shop manual procedures for servicing these heater units. The Ford car SelectAire unit heater core is integral with the evaporator. To service the heater core on this unit, use the following procedure:

REMOVAL. Remove the blower housing assembly (Fig. 40). Drain the engine coolant and disconnect the water hoses from the heater core. Discharge the refrigerant from the system and remove the evaporator core. Remove the four heater core mounting screws and remove the core (Fig. 47).

INSTALLATION. Install the new heater core in the evaporator housing (Fig. 47). Install the evaporator core. Attach the heater hoses, fill the cooling system, and install the blower housing assembly.

Evaporator

The evaporator core of the car SelectAire unit may be removed from the evaporator housing without removing the housing from the car. On both the Thunderbird and PolarAire units, the evaporator and housing assembly must be removed from the vehicle before removing the core from the housing.

CAR POLARAIRE EVAPORATOR REMOVAL. Discharge the refrigerant from the system. Disconnect the

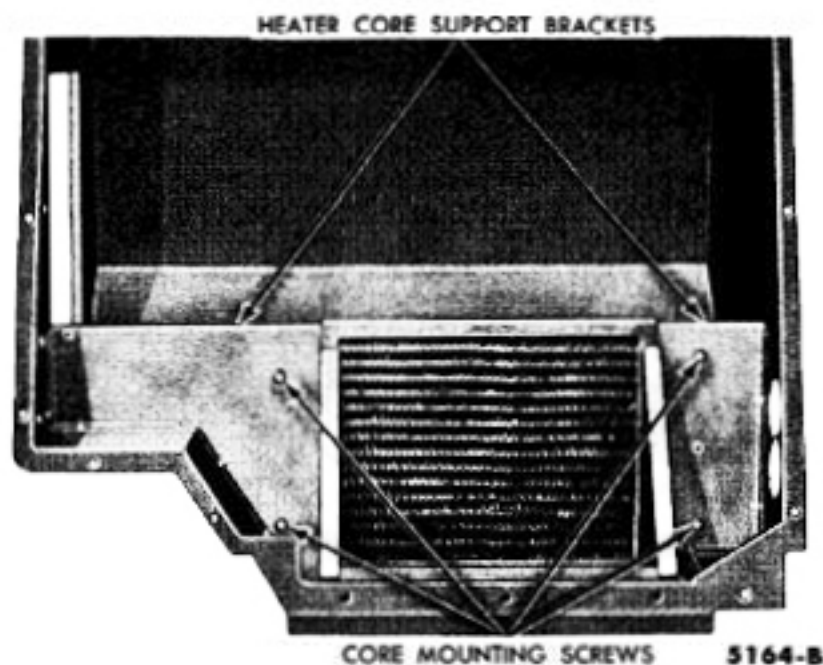

Fig. 47—Heater Core Removal—Car

two wires from the unit. Loosen the support stud under the unit, and remove the two evaporator to instrument panel mounting bolts and set the evaporator on the car floor. Disconnect the refrigerant hoses and remove the unit from the car. Pull off the control knobs and remove the cover. The evaporator core may then be removed after first removing the top mounting plate (Fig. 39).

CAR POLARAIRE EVAPORATOR INSTALLATION. Transfer the old expansion valve to the new evaporator core (Fig. 46). Install the core to the case, and install the temperature sensing tube (Fig. 39). Install the top mounting plate. Make certain that the inlet filter is in position in the expansion valve (Fig. 48), then attach the refrigerant hoses (Fig. 46). Leak test the system, then install the insulation on the expansion valve and refrigerant pipes. Install the cover, mount the assembly under the instrument panel, adjust the support stud and attach the two wires to the unit. Evacuate and charge the system.

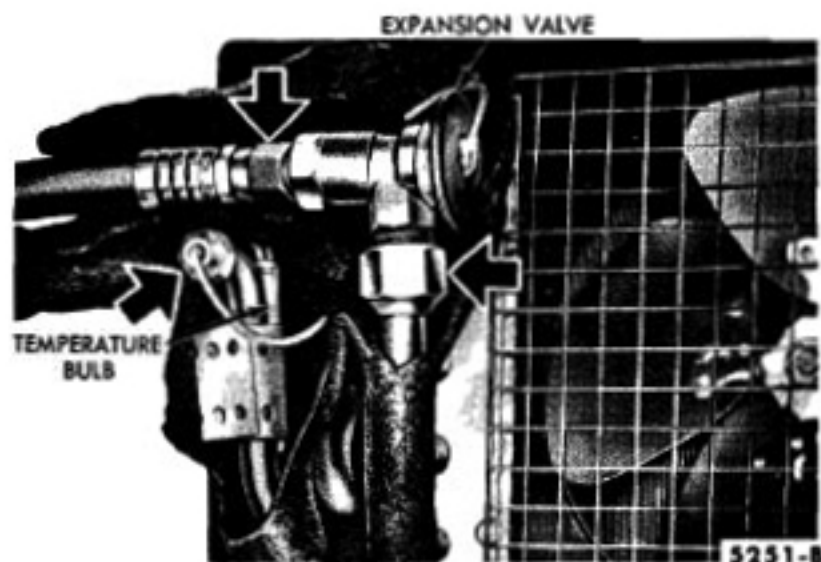

Fig. 46—Evaporator Connections—PolarAire

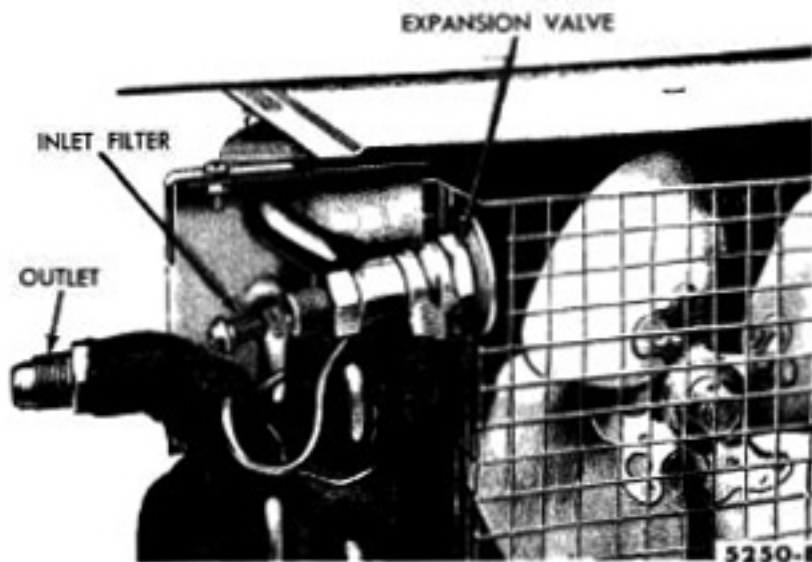

Fig. 48—Inlet Filter—PolarAire

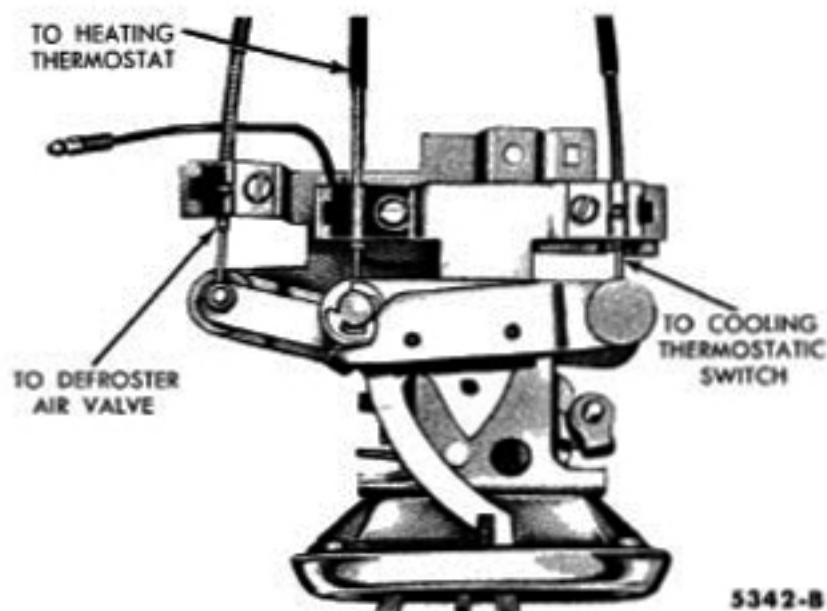

Fig. 49—Control Cable Attachment—Thunderbird

CAR SELECTAIRE EVAPORATOR REMOVAL. Discharge the refrigerant from the system, remove the evaporator bottom cover, and disconnect the refrigerant hoses from the evaporator. Remove the glove box and remove the temperature sensing tube clamp and tube from the evaporator. Disconnect the thermostatic switch mounting brackets from the evaporator housing. Disconnect the switch linkage to air valve control arm spring and position the switch and bracket away from the evaporator housing. Remove the air valve from the valve control arm rod and pull the control arm rod from the evaporator. Remove the eight evaporator core mounting screws and remove the core from the housing.

CAR SELECTAIRE EVAPORATOR INSTALLATION. Transfer the old expansion valve to the new evaporator core and mount the core in the housing. Place the evaporator air valve control arm rod into position and install the air valve to the arm (Fig. 44). Install the thermostatic switch and bracket assembly to the evaporator housing, attach the air valve control arm spring, and check the operation of the thermostatic switch and

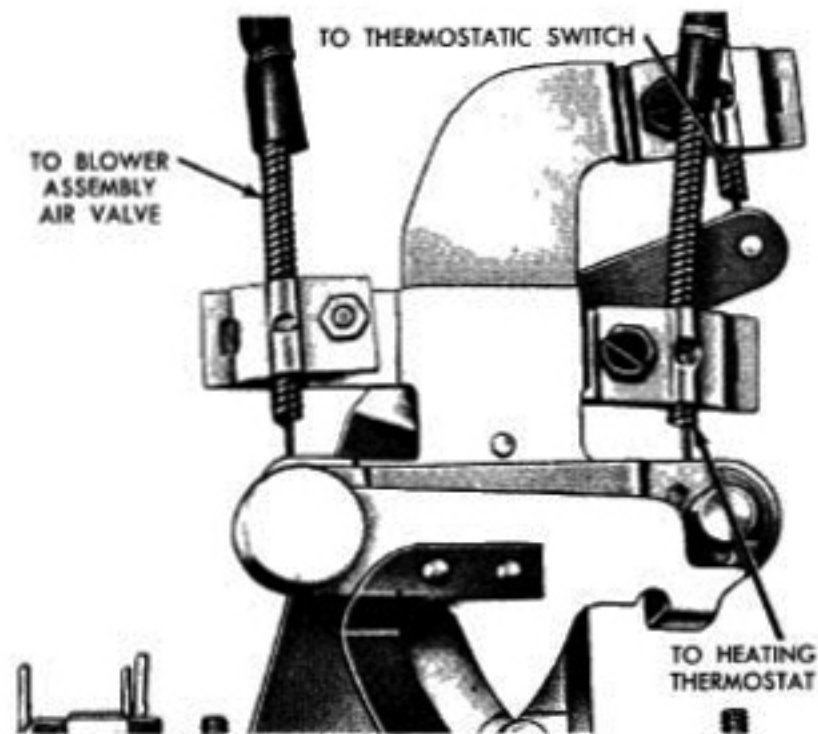

Fig. 50—Control Cable Attachment—Car

the air valve. Attach the refrigerant hoses, leak test the connections, evacuate and charge the system. Install the temperature sensing tube and tube clamp (Fig. 43), then install the glove box. Install the evaporator housing bottom cover.

THUNDERBIRD SELECTAIRE EVAPORATOR REMOVAL. Discharge the refrigerant from the system. Remove the thermostatic switch cover from the evaporator case and disconnect the switch control cable and wires from the switch (Fig. 12). Disconnect the evaporator air valve control cable (Fig. 12). Remove the clamp from between the blower and evaporator housing. Remove the road draft tube from the intake manifold, and disconnect the accelerator linkage. Disconnect the compressor to evaporator and the condenser to evaporator hoses at the evaporator. Remove the two nuts and two screws that hold the evaporator assembly to the dash and remove the evaporator and case assembly.

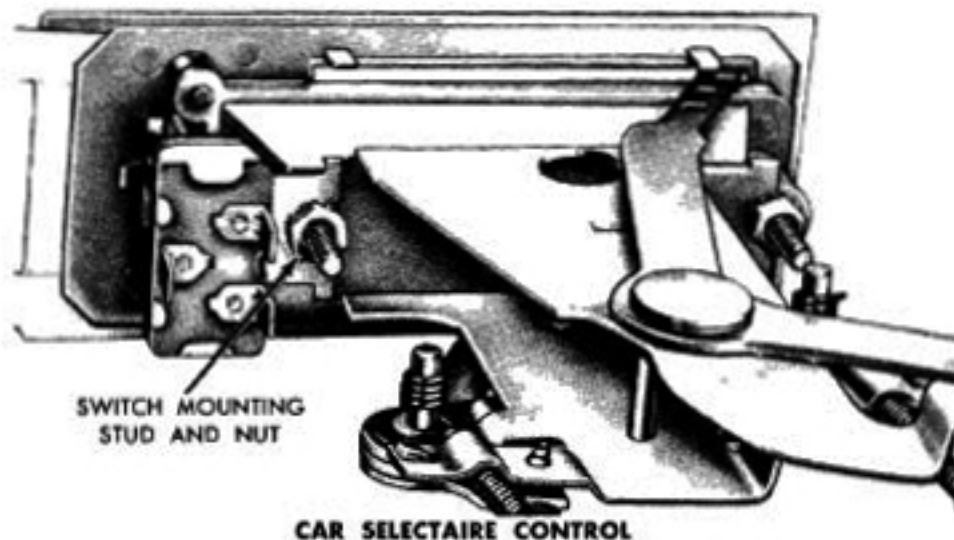

Fig. 51—Blower Switch Removal

The evaporator core may then be removed from the housing by removing the thirteen clips and four screws that retain the cover and removing the two evaporator core to housing mounting screws.

THUNDERBIRD SELECTAIRE EVAPORATOR INSTALLATION. Install the old expansion valve on the new evaporator core, leak test the assembly, place the core on the housing dowel pins and attach the two mounting screws. Attach the housing cover in place and mount the assembly to the dash. Attach the refrigerant hoses to the evaporator (Fig. 45). Install the road draft tube to the intake manifold and connect the accelerator linkage. Connect the thermostatic switch wires and control cable, and the evaporator air valve control cable and adjust both cables. Install the thermostatic switch cover

and then install the blower housing to evaporator housing clamp. Leak test the system, then evacuate and charge the system.

Control Unit

The controls for the car and Thunderbird SelectAire units are located at the same locations as are the heater controls for those vehicles. The PolarAire controls are integral with the evaporator. Pull the control knobs off and remove the evaporator cover for access to the PolarAire controls. When installing a SelectAire control, adjust each Bowden cable for proper operation of the controls. The various cables are attached to the controls as shown in Figs. 49 and 50. The blower switches are attached to the underside of the controls (Fig. 51).

2. CONDENSER AND RECEIVER

If the condenser is to be replaced, remove the original receiver along with the condenser as one assembly; because the replacement condenser is supplied only as one assembly with the receiver. The receiver, however, can be replaced as a separate unit.

Condenser

The condenser is mounted in front of the radiator. To remove the condenser, remove the horns and horn

brackets and remove the grille center support bracket (grille to radiator support bracket on the Thunderbird). Discharge the refrigerant, and disconnect the refrigerant hoses from the condenser and receiver. Remove the four mounting bolts indicated by the large arrows (Fig. 52) and remove the condenser.

On the Thunderbird, removal of the grille to radiator support bracket also removes the top mounting bolts of the condenser (Fig. 53). The condenser lower mounting points, shown by the large arrows in Fig. 53, are held in position by the two radiator lower mounting bolts. Remove the radiator lower mounting bolts, push the top of the radiator backwards a few inches and remove the condenser and receiver assembly.

After installing the condenser assembly, attach the

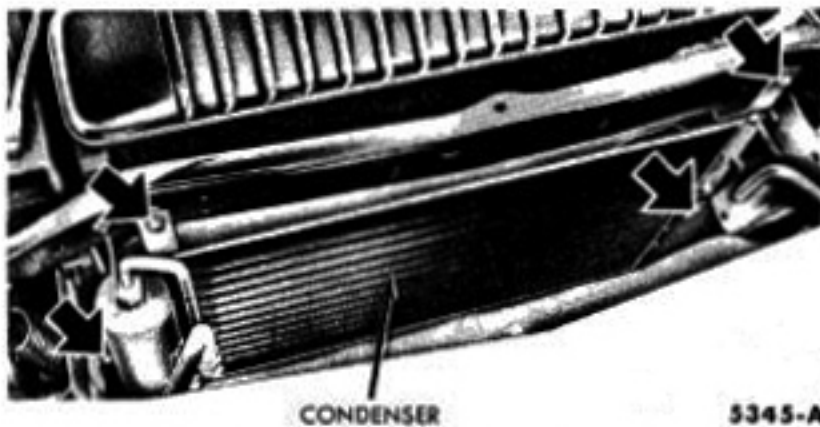

Fig. 52—Condenser Mounting—Car

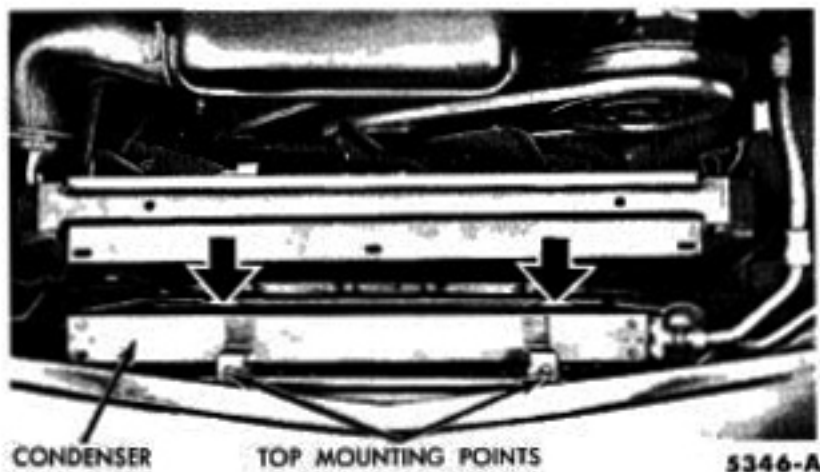

Fig. 53—Condenser Mounting—Thunderbird

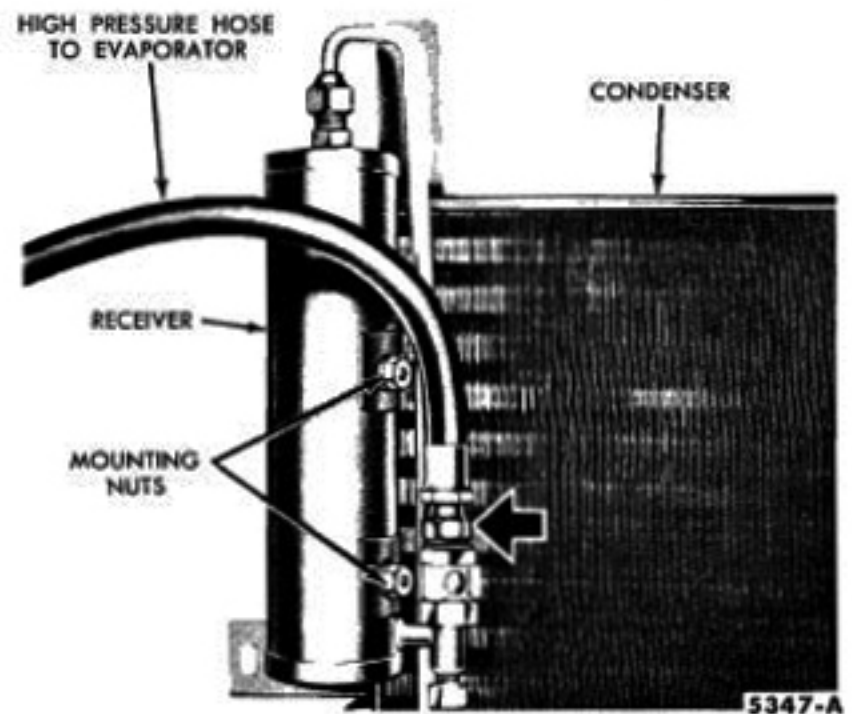

Fig. 54—Receiver Mounted to Condenser—Car

refrigerant hoses, check for leaks, evacuate and charge the system. Install the horns and grille center support bracket.

Receiver

The receiver and sight glass assembly is mounted at the right side of the condenser on the car (Fig. 54), and at the left side of the condenser on the Thunderbird. To remove the receiver, discharge the refrigerant, disconnect the two fittings indicated by the two large

arrows (Fig. 54), remove the mounting nuts and remove the receiver and sight glass assembly. On the Thunderbird, remove the condenser assembly before removing the receiver.

Transfer the old sight glass to the new receiver, position the receiver to the mounting bracket and install the two mounting nuts finger tight (Fig. 54). Connect the copper tube at the top of the receiver, then tighten the receiver mounting nuts. Attach the hose to the sight glass fitting. Test for leaks, evacuate and charge the system.

3. COMPRESSOR SERVICE

All compressor service operations, except belt replacement, can be performed only after the unit has been isolated from the rest of the system as described below.

The compressor is not completely disassembled for service. All necessary repairs can be made by replacement of certain parts which are available in service kits. If none of the service kits restore normal operation, replace the compressor assembly.

Service kits for the valve plates and the suction and discharge fittings can be installed without removing the compressor from the car. Procedures for installing such kits precede compressor replacement. Since replacement of the magnetic clutch or the shaft seal requires

removal of the compressor assembly, service procedures for these items follow compressor replacement.

Isolating The Compressor

To isolate the compressor from the system, turn both the high and the low pressure service valves to the extreme clockwise position (Fig. 33). Loosen the cap on the high pressure service valve gauge port, and allow the gas to escape until the compressor is relieved of refrigerant pressure.

CAUTION: *Loosen the cap a small amount only, and do not remove it until the pressure is completely relieved.*

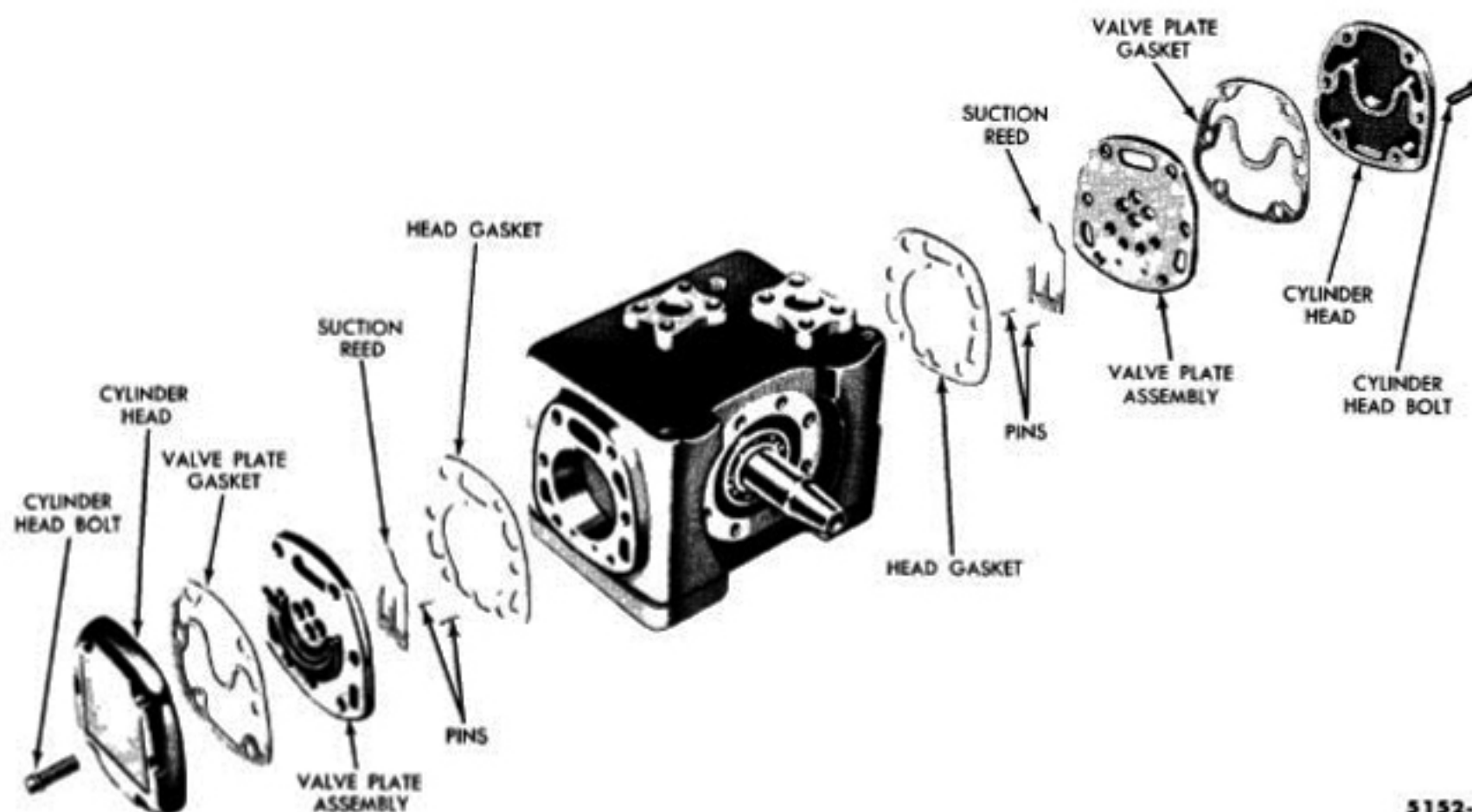

Fig. 55—Tecumseh Compressor Cylinder Head and Valve Assembly

To cut the compressor back into the system, evacuate the compressor at the high pressure service valve gauge port, shut off the vacuum pump, turn both service valves to the maximum counterclockwise position, and cap the high pressure service valve gauge port and service valve stems.

Valve Plate Replacement

Isolate the compressor, then remove the ten head bolts (on the Lehigh compressor, disconnect the service valves before removing the head bolts).

Tap the cylinder head and valve plate lightly to loosen them, and remove these parts from the top of the compressor body (Fig. 55 or 56).

CAUTION: *Be careful not to shear off the valve plate locating pins (Fig. 55 or 56).*

Remove and discard all gaskets, and be sure to clean gasket shreds from all gasket surfaces. Examine the cylinders and top of the pistons, particularly in case of valve breakage. If there are score marks, replace the compressor assembly.

If the cylinders and pistons are in good condition, check the valve plate and suction valve leaves for scratches or damage. If the suction valve leaves and plate assembly are in good condition, they can both be used again. If the valve plate is damaged, install the entire replacement kit which includes the valve plate, valve leaves, and the two gaskets (Fig. 55 or 56).

When either the valve leaves or plate assembly are reused, wash them in clean solvent and dry them in dry air. Check the oil for dirt. If the system is not clean, replace the oil.

CAUTION: *If the valve plate and leaves are reused, be sure to replace the leaves in their original positions on the valve plate.*

Starting with valve plate gasket, assemble the parts in the order shown in Fig. 55 or 56. Before installing the valve leaves and plate assembly, dip the valve leaves in clean refrigeration oil, and mount them on the pins that are pressed in the underside of the valve plate. The oil will hold the leaves to the plate as it is being assembled. Insert the cylinder head bolts carefully to avoid damaging the gaskets.

Tighten all bolts finger tight, then tighten the bolts a quarter turn at a time to 15-20 foot pounds torque.

Check the oil level in the compressor and add oil if necessary. Check the compressor volumetric efficiency, then connect the compressor into the system.

Service Valve Replacement

Discharge the refrigerant from the system. Remove the refrigerant hoses from the valves. Remove the attaching screws, fittings and gaskets.

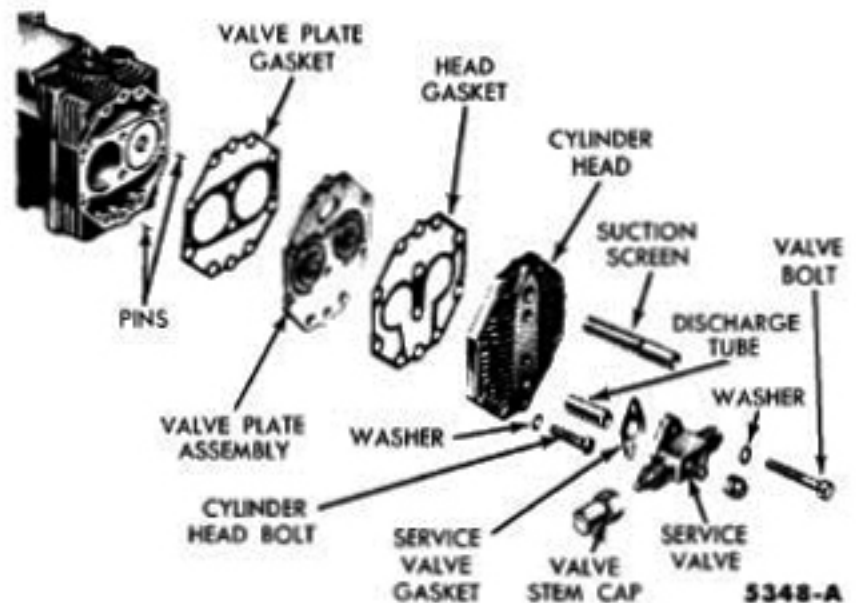

Fig. 56—Lehigh Compressor Cylinder Head and Valve Assembly

Install the necessary replacement parts as shown in Fig. 56 or 57. If the strainer in the low pressure service valve fitting is not being replaced, clean it before installing it (install a new strainer gasket on the Tecumseh Compressor).

Compressor Replacement

Isolate the compressor and disconnect the two service valves and hoses from the compressor. Energize the clutch and loosen the clutch mounting bolt. Disconnect the clutch wire at the bullet connector. Loosen the

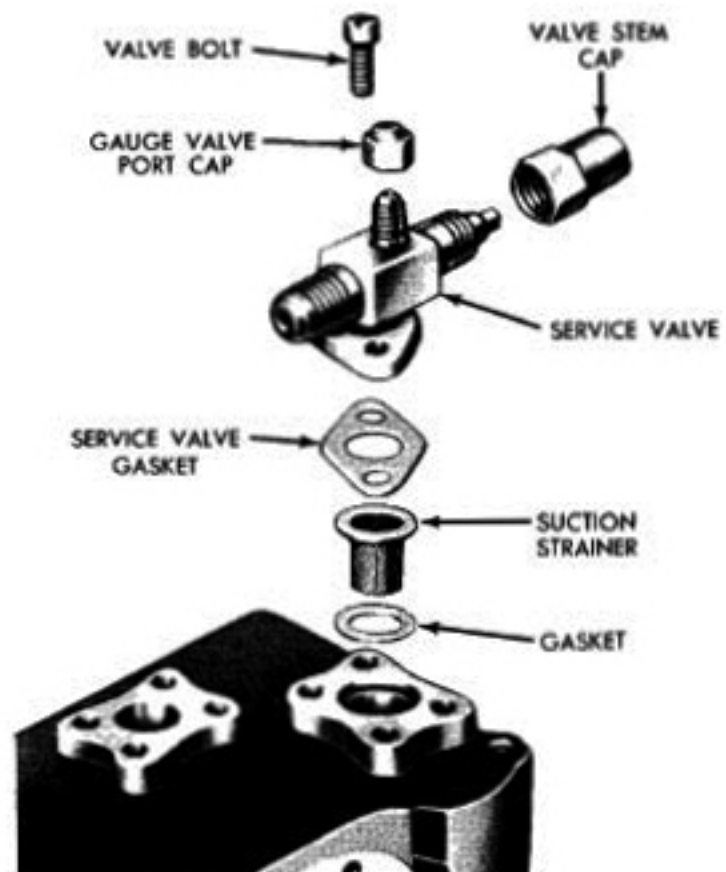

Fig. 57—Service Valve Replacement—Tecumseh



Fig. 58—Compressor Mounting—Typical

compressor mounting bolts (large arrows, Fig. 58). Slide the compressor toward the center of the engine, remove the drive belt, then remove the mounting bolts and the compressor.

With the compressor on the work bench, remove the clutch mounting screw and washer, remove the clutch from the shaft (use a wheel puller), then remove the key from the shaft.

Carefully remove any burrs or dirt that may be on

the new compressor shaft, then install the key in the shaft. Mount the clutch on the shaft and install the mounting screw and washer finger tight. Place the compressor on the mounting bracket and install the four mounting bolts finger tight (Fig. 58). Connect the clutch wire, energize the clutch and tighten the clutch mounting bolt to 18-22 foot-pounds torque. *If the new compressor was shipped with a bolt and washer in the end of the crankshaft, remove and discard the bolt and use a bolt with a nylon insert in it.* Install the drive belt and tighten the mounting bolts.

Install the service valves on the compressor (Fig. 59), using new gaskets. Leak test the compressor, then evacuate it and cut it back into the system.

Crankshaft Seal Replacement—Tecumseh

Energize the clutch and loosen the clutch mounting bolt. Remove the compressor from the car, and remove the clutch and key from the compressor shaft. Use a wheel puller when removing the clutch. A disassembled view of the Tecumseh crankshaft seal assembly is shown in Fig. 60.

Remove the slip ring brush assembly. Compress the bellows assembly with the special tool (Fig. 61), remove the snap ring, and remove the bellows assembly.

Remove the bearing support plate mounting screws. Mount the bearing support plate removing tool to the plate (Fig. 62) using the two threaded holes in the plate, and remove the plate. Press the bearing plate carbon seal from the plate and remove the "O" ring. Clean all old gasket material from the bearing plate and the compressor.

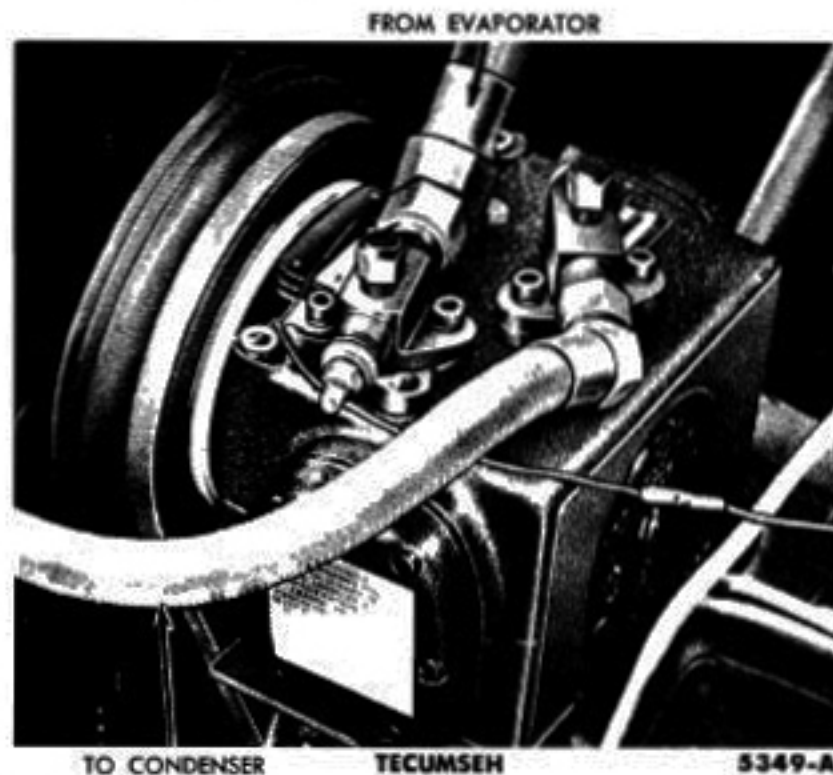
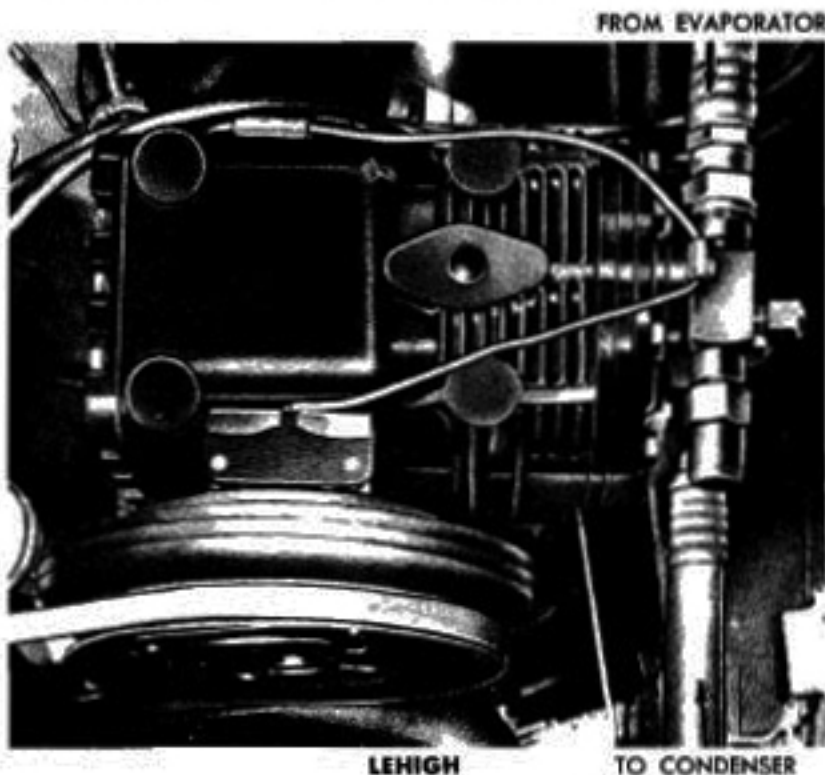

Fig. 59—Compressor Hose Connections

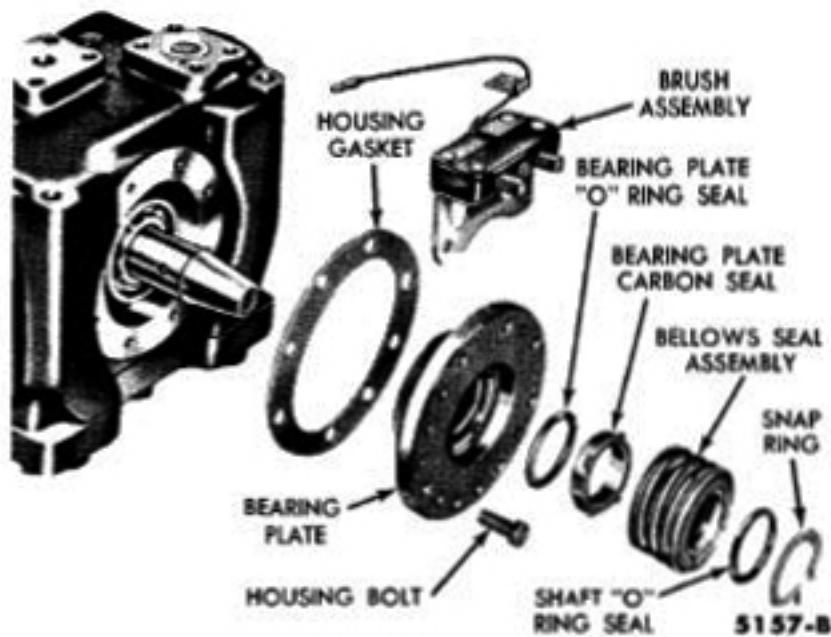

Fig. 60—Crankshaft Seal Assembly—Tecumseh

CAUTION: Do not force the bearing support plate from its seat with the use of two screws through the threaded holes in the plate, as this will put undue force on the crank rear bearing. Always use the removing tool.

Lubricate the new shaft seal parts in clean compressor oil. Install the new "O" ring in the bearing plate and carefully insert the new carbon seal into place.

Attach the bearing plate mounting tool to the plate, position the new gasket and force the bearing plate into position (Fig. 63). When the plate is nearly in position, rotate it so that two bearing plate mounting bolts may be installed to act as guides, and seat the plate with the installing tool. Remove the tool and install and tighten the bearing plate mounting bolts.

Place the bellows seal assembly in position and compress the bellows with the mounting tool (Fig. 61), then install the snap ring. Remove the tool and install

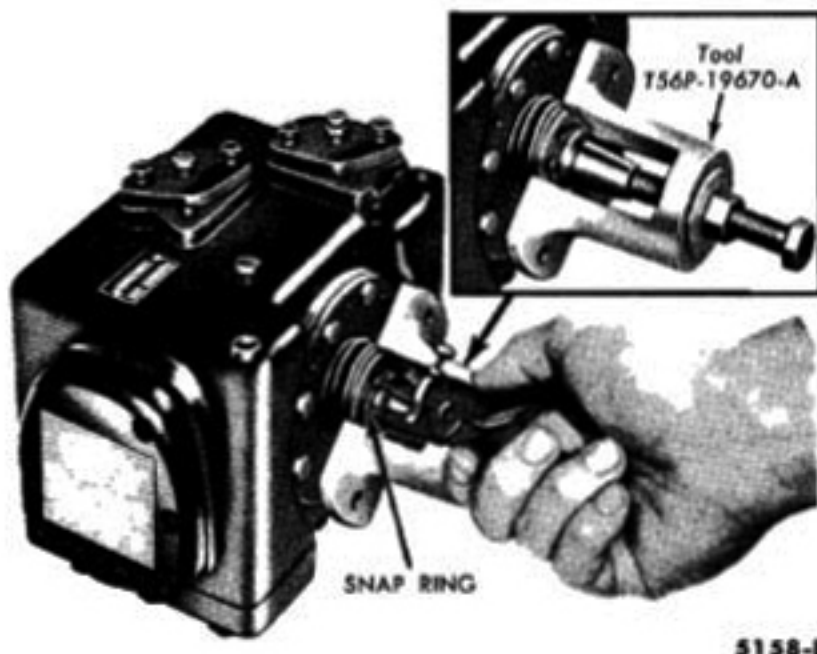

Fig. 61—Compressing Bellows

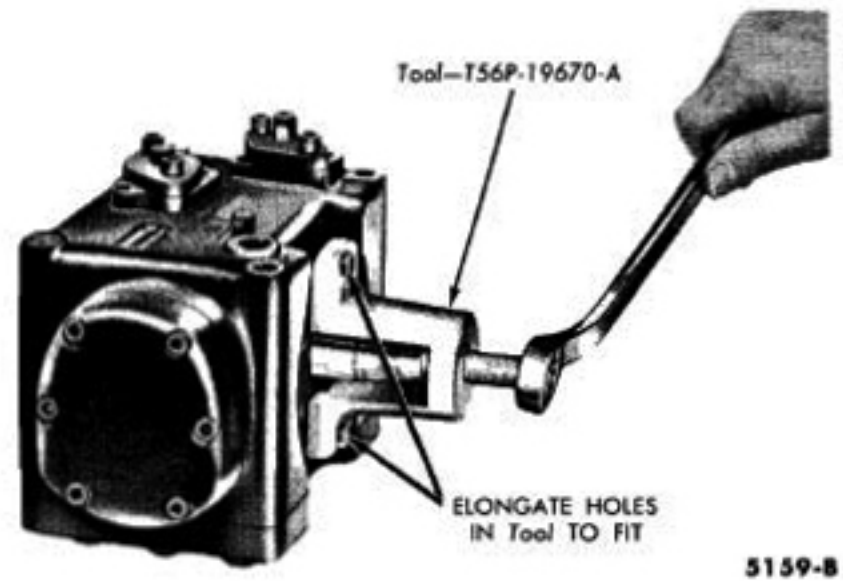

Fig. 62—Removing Bearing Support Plate

the slip ring brush assembly (Fig. 9), key and clutch. Make certain that there are no burrs or dirt on the compressor shaft before installing the key and clutch. Install the clutch mounting bolt and washer. Tighten to 18-22 foot pounds torque. Install the compressor in the car.

Crankshaft Seal Replacement—Lehigh

Energize the clutch and loosen the clutch mounting bolt. Remove the compressor from the car. Remove the magnetic clutch (using a wheel puller) and the slip ring brush assembly. Remove the remaining seal plate bolts, then remove the plate and gasket. Remove the carbon seal ring and seal housing assembly from the crankshaft. A disassembled view of the Lehigh crankshaft seal assembly is shown in Fig. 64.

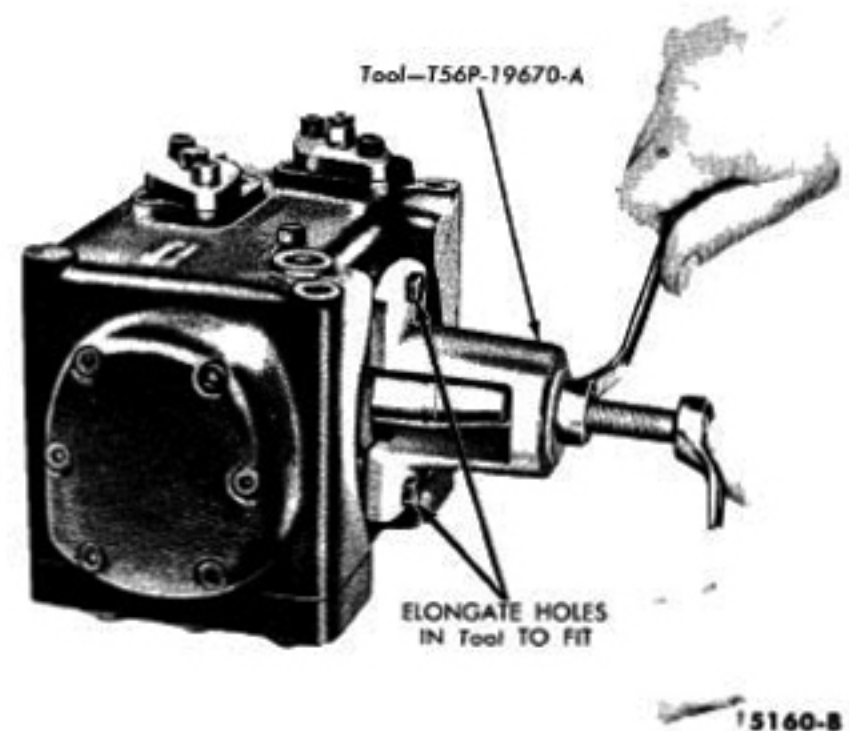

Fig. 63—Installing Bearing Support Plate

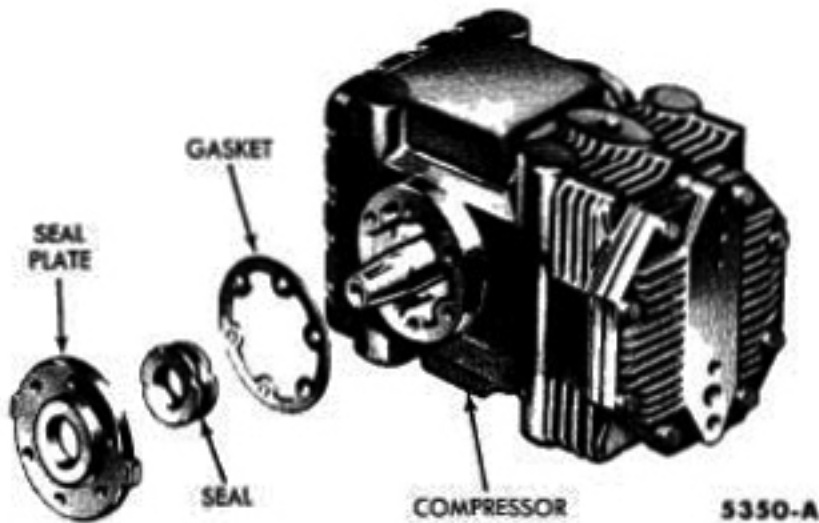

Fig. 64—Crankshaft Seal Assembly—Lehigh

Clean all old gasket material from the seal plate and the compressor. Make certain that the shaft, seal plate and compressor gasket surfaces are completely clean before installing the new seal.

Lubricate the new shaft seal parts in clean compressor oil. Position the seal assembly on the crankshaft, engaging the notches in the seal with the locating pins (Fig. 65). Position the new gasket on the compressor and install the seal plate, attaching the slip ring brush assembly with two of the seal plate bolts. Tighten the bolts to 6-9 foot-pounds torque. Install the compressor in the car, and install the magnetic clutch.

Belt Replacement

Belt replacement is accomplished in the same manner

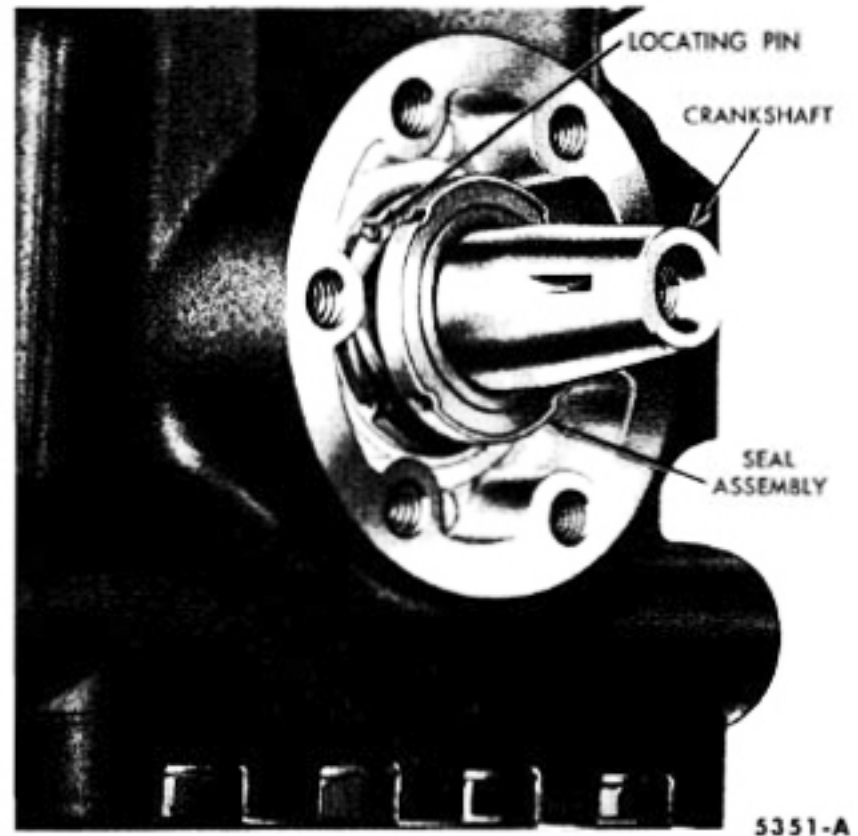

Fig. 65—Crankshaft Seal Installation—Lehigh

for both the Tecumseh and Lehigh compressors. Loosen the four compressor mounting bolts (Fig. 58). Slide the compressor toward the center of the vehicle and remove the belt.

Place the new belt in position, slide the compressor toward the outside of the vehicle and tighten the four mounting nuts (Fig. 58).